



Blanc ON-OFF Series

Service Manual 2016



MSMA1A-07HRN1 / MOAB02-07HN1
MSMA1A-09HRN1 / MOAB02-09HN1
MSMA1B-12HRN1 / MOBA01-12HN1
MSMA1C-18HRN1 / MOBA03-18HN1
MSMA1D-24HRN1 / MOCA02-24HN1



CONTENTS

1. Precaution	3
1.1 Safety Precaution	3
1.2 Warning	3
2. Function.....	6
3. Specification	7
4. Dimension	11
4.1 Indoor Unit.....	11
4.2 Outdoor Unit.....	15
5. Capacity tables.....	19
6. Refrigerant Cycle Diagram	24
7. Installation Details	25
7.1 Wrench torque sheet for installation	25
7.2 Connecting the cables.....	25
7.3 Pipe length and the elevation	26
7.4 Installation for the first time.....	27
7.5 Adding the refrigerant after running the system for many years	29
7.6 Re-installation while the indoor unit need to be repaired	30
7.7 Re-installation while the outdoor unit need to be repaired.....	31
8. Wiring Diagram	33
8.1 Indoor Unit.....	33
8.2 Outdoor Unit.....	35
9. Operation Characteristics.....	37
10. Electronic function	38
10.1 Abbreviation	38
10.2 Display function.....	38
10.3 Main Protection	40
10.4 Operation Modes and Functions	40
11. Troubleshooting.....	48
11.1 Indoor Unit Error Display	48
11.2 Trouble shooting	49

1. Precaution

1.1 Safety Precaution

- To prevent injury to the user or other people and property damage, the following instructions must be followed.
- Incorrect operation due to ignoring instruction will cause harm or damage.
- Before service the unit, be sure to read this service manual at first.

1.2 Warning

➤ Installation

- Do not use a defective or underrated circuit breaker. Use this appliance on a dedicated circuit.

There is risk of fire or electric shock.

- For electrical work, contact the dealer, seller, a qualified electrician, or an authorized service center.

Do not disassemble or repair the product, there is risk of fire or electric shock.

- Always ground the product.

There is risk of fire or electric shock.

- Install the panel and the cover of control box securely.

There is risk of fire or electric shock.

- Always install a dedicated circuit and breaker.

Improper wiring or installation may cause fire or electric shock.

- Use the correctly rated breaker or fuse.

There is risk of fire or electric shock.

- Do not modify or extend the power cable.

There is risk of fire or electric shock.

- Do not install, remove, or reinstall the unit by yourself (customer).

There is risk of fire, electric shock, explosion, or injury.

- Be caution when unpacking and installing the product.

Sharp edges could cause injury, be especially careful of the case edges and the fins on the condenser and evaporator.

- For installation, always contact the dealer or an authorized service center.

- Do not install the product on a defective installation stand.

- Be sure the installation area does not deteriorate with age.

If the base collapses, the air conditioner could fall with it, causing property damage, product failure, and personal injury.

- Do not let the air conditioner run for a long time when the humidity is very high and a door or a window is left open.

- Take care to ensure that power cable could not be pulled out or damaged during operation.

There is risk of fire or electric shock.

- Do not place anything on the power cable.

There is risk of fire or electric shock.

- Do not plug or unplug the power supply plug during operation.

There is risk of fire or electric shock.

- **Do not touch (operation) the product with wet hands.**
- **Do not place a heater or other appliance near the power cable.**

There is risk of fire and electric shock.

- **Do not allow water to run into electrical parts.**

It may cause fire, failure of the product, or electric shock.

- **Do not store or use flammable gas or combustible near the product.**

There is risk of fire or failure of product.

- **Do not use the product in a tightly closed space for a long time.**

Oxygen deficiency could occur.

- **When flammable gas leaks, turn off the gas and open a window for ventilation before turn the product on.**

- **If strange sounds or smoke comes from product, turn the breaker off or disconnect the power supply cable.**

There is risk of electric shock or fire.

- **Stop operation and close the window in storm or hurricane. If possible, remove the product from the window before the hurricane arrives.**

There is risk of property damage, failure of product, or electric shock.

- **Do not open the inlet grill of the product during operation. (Do not touch the electrostatic filter, if the unit is so equipped.)**

There is risk of physical injury, electric shock, or product failure.

- **When the product is soaked, contact an authorized service center.**

There is risk of fire or electric shock.

- **Be caution that water could not enter the product.**

There is risk of fire, electric shock, or product damage.

- **Ventilate the product from time to time when operating it together with a stove etc.**

There is risk of fire or electric shock.

- **Turn the main power off when cleaning or maintaining the product.**

There is risk of electric shock.

- **When the product is not be used for a long time, disconnect the power supply plug or turn off the breaker.**

There is risk of product damage or failure, or unintended operation.

- **Take care to ensure that nobody could step on or fall onto the outdoor unit.**

This could result in personal injury and product damage.

➤ CAUTION

- **Always check for gas (refrigerant) leakage after installation or repair of product.**

Low refrigerant levels may cause failure of product.

- **Install the drain hose to ensure that water is drained away properly.**

A bad connection may cause water leakage.

- **Keep level even when installing the product.**

It can avoid vibration of water leakage.

- **Do not install the product where the noise or hot air from the outdoor unit could damage the neighborhoods.**

It may cause a problem for your neighbors.

- **Use two or more people to lift and transport the product.**

- **Do not install the product where it will be exposed to sea wind (salt spray) directly.**

It may cause corrosion on the product. Corrosion, particularly on the condenser and evaporator fins, could cause product malfunction or inefficient operation.

➤ **Operational**

- **Do not expose the skin directly to cool air for long time. (Do not sit in the draft).**
- **Do not use the product for special purposes, such as preserving foods, works of art etc.**

It is a consumer air conditioner, not a precision refrigerant system.

There is risk of damage or loss of property.

- **Do not block the inlet or outlet of air flow.**
- **Use a soft cloth to clean. Do not use harsh detergents, solvents, etc.**

There is risk of fire, electric shock, or damage to the plastic parts of the product.

■ **Do not touch the metal parts of the product when removing the air filter. They are very sharp.**

- **Do not step on or put anything on the product. (outdoor units)**
- **Always insert the filter securely. Clean the filter every two weeks or more often if**

necessary.

A dirty filter reduces the efficiency of the air conditioner and could cause product malfunction or damage.

■ **Do not insert hands or other objects through air inlet or outlet while the product is operated.**

- **Do not drink the water drained from the product.**
- **Use a firm stool or ladder when cleaning or maintaining the product.**

Be careful and avoid personal injury.

■ **Replace the all batteries in the remote control with new ones of the same type. Do not mix old and new batteries or different types of batteries.**

There is risk of fire or explosion.

- **Do not recharge or disassemble the batteries. Do not dispose of batteries in a fire.**
- They may burn or explode.

■ **If the liquid from the batteries gets onto your skin or clothes, wash it well with clean water. Do not use the remote of the batteries have leaked.**

2. Function

Model Names of Indoor/Outdoor Units

	Capacity	Indoor units	Outdoor units
On-Off	7k	MSMA1A-07HRN1	MOAB02-07HN1
	9k	MSMA1A-09HRN1	MOAB02-09HN1
	12k	MSMA1B-12HRN1	MOBA01-12HN1
	18k	MSMA1C-18HRN1	MOBA03-18HN1
	24k	MSMA1D-24HRN1	MOCA02-24HN1

3. Specification

Indoor model name			MSMA1A-07HRN1	MSMA1A-09HRN1	MSMA1B-12HRN1
Outdoor model name			MOAB02-07HN1	MOAB02-09HN1	MOBA01-12HN1
Power supply		Ph-V-H z	220-240V- 50Hz, 1Ph	220-240V- 50Hz, 1Ph	220-240V- 50Hz, 1Ph
Cooling	Capacity	Btu/h	7000	9000	12000
		kW	2,05	2,64	3,52
	Input	W	639	822	1096
	Rated current	A	2.8	3.6	4.8
	EER	W/W	3,21	3,21	3,21
Heating	Capacity	Btu/h	8000	9500	13000
		kW	2,34	2,78	3,81
	Input	W	649	771	1055
	Rated current	A	2.8	3.4	4.8
COP	W/W	3,61	3,61	3,61	
Max. input consumption		W	1050	1200	1800
Max. current		A	5.5	6.0	9.0
Starting current		A	16.1	21.7	25
Compressor	Model		ASN82V1UDZ	44M213AH&FJKC	ASM140V1VFT
	Type		ROTARY	ROTARY	ROTARY
	Brand		GMCC	Rechi	GMCC
	Capacity	Btu/h	6995/7029	8428/8530	13853/13853
	Input	W	702/735	830/860	955/995
	Rated current(RLA)	A	3.21/3.15	3.85/3.73	4.35/4.2
	Locked rotor Amp(LRA)	A	16.1	21.7	25
	Thermal protector		----	B160-135-241E	/
	Thermal protector position		EXTERNAL	EXTERNAL	INTERNAL
	Capacitor	uF	25	40	35
	Refrigerant oil/oil charge	ml	ESTEL OIL VG74/300	ESTER OIL VG74 350cc	ESTER OIL VG74/350
Indoor fan motor	Model		YKFG-13-4-38L	YKFG-13-4-38L	YKFG-13-4-38L
	Input	W	40	40	40
	Capacitor	uF	1.2	1.2	1.2
	Speed(Hi/Mi/Lo)	r/min	1050/950/800	1100/950/800	1150/950/800
Indoor coil	a.Number of rows		2	2	2
	b.Tube pitch(a)x row pitch(b)	mm	19.5x11.6	19.5x11.6	19.5x11.6
	c.Fin spacing	mm	1.2	1.2	1.2
	d.Fin type (code)		Hydrophilic aluminium	Hydrophilic aluminium	Hydrophilic aluminium
	e.Tube outside dia.and type	mm	Φ5,innergroove tube	Φ5,innergroove tube	Φ5,innergroove tube

	f.Coil length x height x width	mm	510x253x23.2	510x253x23.2	595x78x23.2+595x117x23.2+595x78x23.2
	g.Number of circuits		3	3	4
Indoor air flow (Hi/Mi/Lo)		m3/h	436/381/300	456/380/306	564/436/342
Indoor noise level (Hi/Mi/Lo)		dB(A)	36.0/34/30	39/34/29	42/38/36
Indoor unit	Dimension(W*D*H)	mm	715*285*194	715*285*194	805x205x285
	Packing (W*D*H)	mm	765*270*345	765*270*345	870*285*360
	Net/Gross weight	Kg	7.1/9.3	7.1/9.3	8.0/10.3
Outdoor fan motor	Model		YKT-32-6-203L	YKT-32-6-203L	YKT-32-6-203L
	Input	W	72.5	72.5	72.5
	Capacitor	uF	2.5	2.5	2.5
	Speed	r/min	850	850	850
Outdoor coil	a.Number of rows		1	1	1
	b.Tube pitch(a)x row pitch(b)	mm	21x13.37	21x13.37	21x22
	c.Fin spacing	mm	1.4	1.4	1.2
	d.Fin type (code)		Hydrophilic aluminium	Hydrophilic aluminium	Hydrophilic aluminium
	e.Tube outside dia.and type	mm	Φ7,innergroove tube	Φ7,innergroove tube	Φ7,innergroove tube
	f.Coil length x height x width	mm	685x508x13.37	685x508x13.37	744x504x22
	g.Number of circuits		2	2	2
Outdoor noise level		dB(A)	54	55	57
Outdoor unit	Dimension(W*D*H)	mm	700x270x550	700x270x550	770x300x555
	Packing (W*D*H)	mm	815x325x615	815x325x615	900x345x585
	Net/Gross weight	Kg	23.1/25.2	25.3/27.6	29.5/32.0
Refrigerant type		g	R410A/520g	R410A/590g	R410A/740g
Design pressure		MPa	4.2/1.5	4.2/1.5	4.2/1.5
Refrigerant piping	Liquid side/ Gas side	mm(inc h)	Φ6.35/Φ9.52(1/4"/3/8")	Φ6.35/Φ9.52(1/4"/3/8")	Φ6.35/Φ12.7(1/4"/1/2")
	Max. refrigerant pipe length	m	20	20	20
	Max. difference in level	m	8	8	8
Connection wiring			5x1.0(Optional)	5x1.0(Optional)	3x1.5+2x0.75(Optional)
Plug type			3x1.5 / VDE	3x1.5 / VDE	3x1.5 / VDE
Remote Control			RG70A/BGEF	RG70A/BGEF	RG70A/BGEF
Operation temperature		℃	17-30	17-30	17-30
Room temperature	Indoor(cooling/ heating)	℃	17-32/0-30	17-32/0-30	17-32/0-30
	Outdoor(cooling/heating)	℃	18-43/-7-24	18-43/-7-24	18-43/-7-24
Application area (Cooling Standard)		m2	10-15	12-18	16-23

Indoor model name			MSMA1C-18HRN1	MSMA1D-24HRN1
Outdoor model name			MOBA03-18HN1	MOCA02-24HN1
Power supply		Ph-V-Hz	220-240V- 50Hz, 1Ph	220-240V- 50Hz, 1Ph
Cooling	Capacity	Btu/h	18000	24000
		kW	5,28	7,03
	Input	W	1643	2503
	Rated current	A	7.1	10.9
EER	W/W	3,21	2,81	
Heating	Capacity	Btu/h	19000	26000
		kW	5,57	7,62
	Input	W	1543	2374
	Rated current	A	6.7	10.3
COP	W/W	3,61	3,21	
Max. input consumption		W	2400	4000
Max. current		A	12	20
Starting current		A	/	54.5
Compressor	Model		ASL211SV-C7LU1	PA280G2CS-4MTL
	Type		ROTARY	ROTARY
	Brand		HITACHI	GMCC
	Capacity	Btu/h	17299/-	27705/27824
	Input	W	1750/-	1910/1990
	Rated current(RLA)	A	4.75	8.8/8.05
	Locked rotor Amp(LRA)	A	/	54.5
	Thermal protector		/	
	Thermal protector position		INTERNAL	INTERNAL
	Capacitor	uF	50	60
Refrigerant oil/oil charge	ml	ESTER OIL VG74/350	ESTER OIL VG74/850	
Indoor fan motor	Model		YKFG-25-4-6	YKFG-45-4-22
	Input	W	62	45
	Capacitor	uF	1.5	3
	Speed(Hi/Mi/Lo)	r/min	1180/1000/850	1200/1000/850
Indoor coil	a.Number of rows		2	2
	b.Tube pitch(a)x row pitch(b)	mm	21x13.37	21x13.37
	c.Fin spacing	mm	1.2	1.2
	d.Fin type (code)		Hydrophilic aluminium	Hydrophilic aluminium
	e.Tube outside dia.and type	mm	Φ7,innergroove tube	Φ7,innergroove tube
	f.Coil length x height x width	mm	750x84x26.74+750x147x26.74	780x210x26.74+780x105x26.74
	g.Number of circuits		3	4
Indoor air flow (Hi/Mi/Lo)		m3/h	776/645/523	1010/810/659
Indoor noise level (Hi/Mi/Lo)		dB(A)	42/38/35	47/41.5/37
Indoor unit	Dimension(W*D*H)	mm	957x223x302	1040x235x327
	Packing (W*D*H)	mm	1035*305*380	1120*405*330
	Net/Gross weight	Kg	10.2/13.3	12.9/16.4

Outdoor fan motor	Model		YKT-48-6-206	YKT-75-6-200L
	Input	W	93	75
	Capacitor	uF	3	3
	Speed	r/min	880	850
Outdoor coil	a.Number of rows		2	2
	b.Tube pitch(a)x row pitch(b)	mm	21x13.37	21x13.37
	c.Fin spacing	mm	1.4	1.5
	d.Fin type (code)		Hydrophilic aluminium	Hydrophilic aluminium
	e.Tube outside dia.and type	mm	Φ7,innergroove tube	Φ7,innergroove tube
	f.Coil length x height x width	mm	755x504x26.74	740x630x13.37+760*630*13.37
	g.Number of circuits		4	6
Outdoor noise level		dB(A)	58	59
Outdoor unit	Dimension(W*D*H)	mm	770x300x555	845x363x702
	Packing (W*D*H)	mm	900x345x585	965x395x755
	Net/Gross weight	Kg	34.9/37.3	49.2/52.4
Refrigerant type		g	R410A/1150g	R410A/1750g
Design pressure		MPa	4.2/1.5	4.2/1.5
Refrigerant piping	Liquid side/ Gas side	mm(inch)	Φ6.35/Φ12.7(1/4"/1/2")	Φ9.52/Φ16(3/8"/5/8")
	Max. refrigerant pipe length	m	25	25
	Max. difference in level	m	10	10
Connection wiring			3x1.5+2x0.75(Optional)	4x1.0(Optional)
Plug type			1.5x3	-----
Remote Control			RG70A/BGEF	RG70A/BGEF
Operation temperature		℃	17-30	17-30
Room temperature	Indoor(cooling/ heating)	℃	17-32/0-30	17-32/0-30
	Outdoor(cooling/heating)	℃	18-43/-7-24	18-43/-7-24
Application area (Cooling Standard)		m2	24-35	32-47

4. Dimension

4.1 Indoor Unit

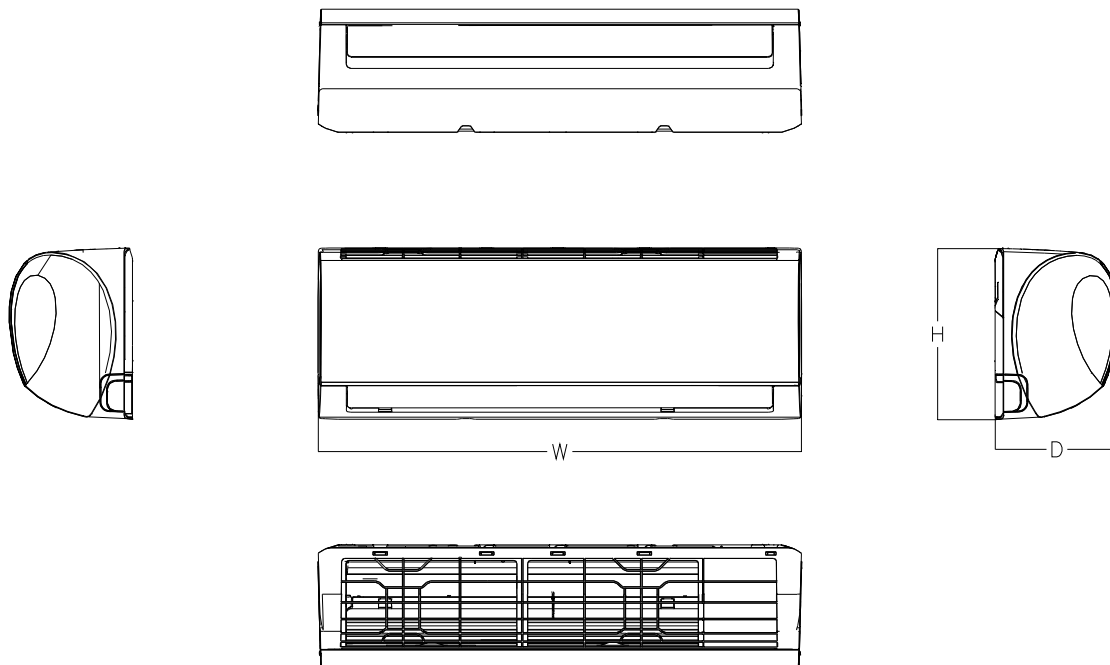

Model	W	D	H
MSMA1A-07HRN1	715	194	285
MSMA1A-09HRN1	715	194	285
MSMA1B-12HRN1	805	205	285
MSMA1C-18HRN1	957	233	302
MSMA1D-24HRN1	1040	235	327

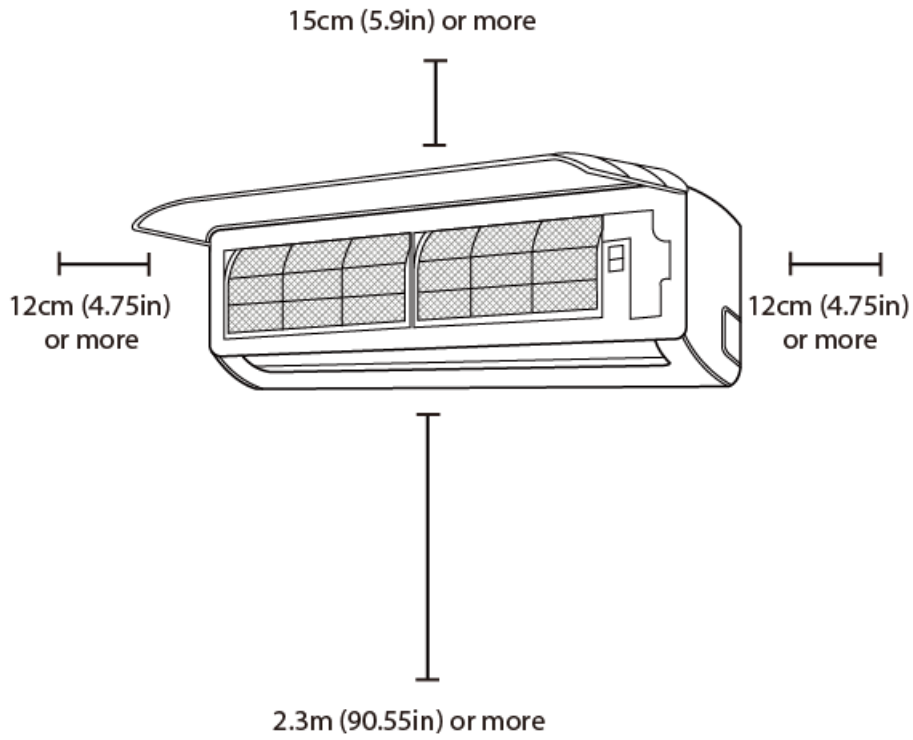

For MSMA1A-07HRN1, MSMA1A-09HRN1,

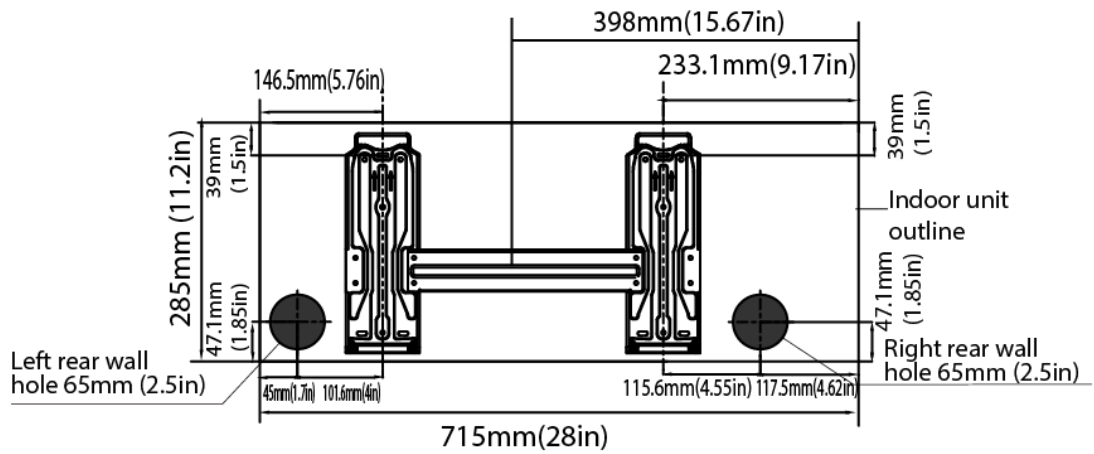

Model A

For MSMA1B-12HRN1,

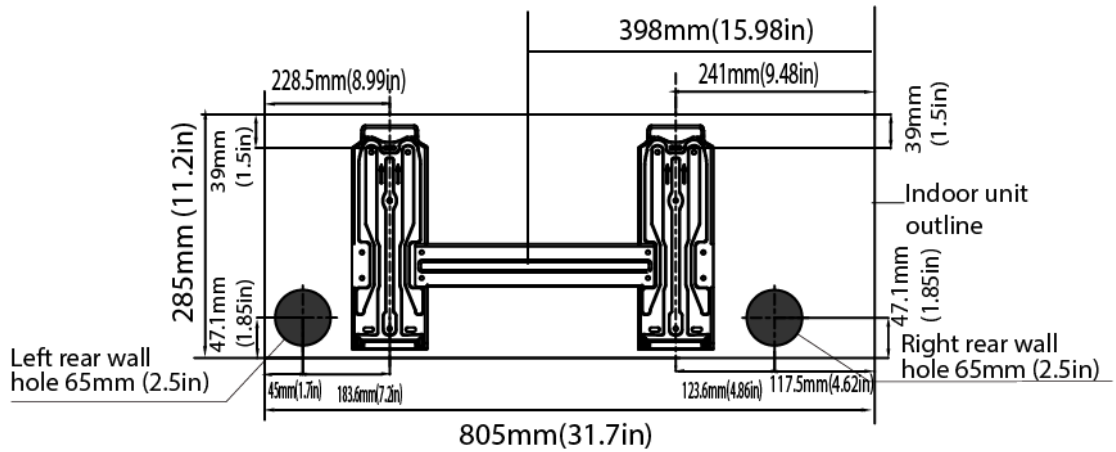

Model B

For MSMA1C-18HRN1,

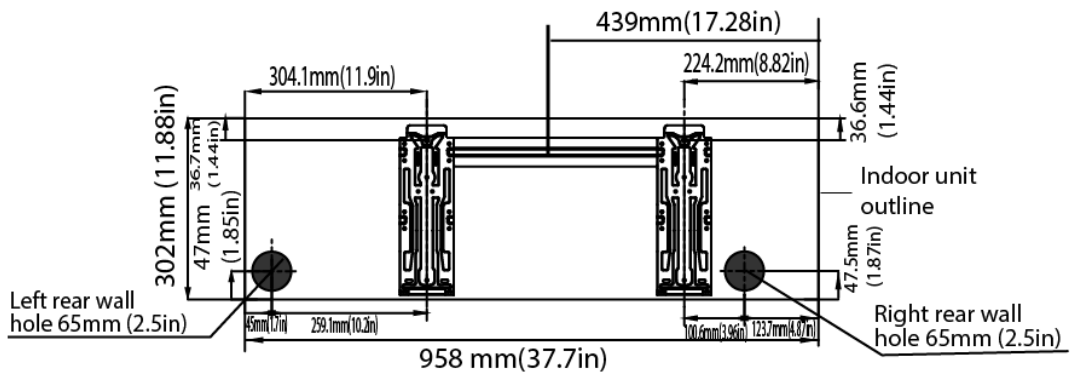

Model C

For MSMA1D-24HRN1,

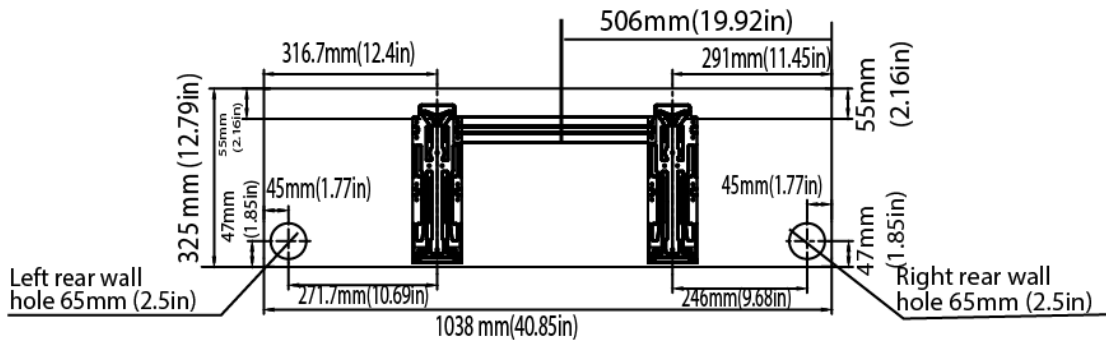

Model D

4.2 Outdoor Unit

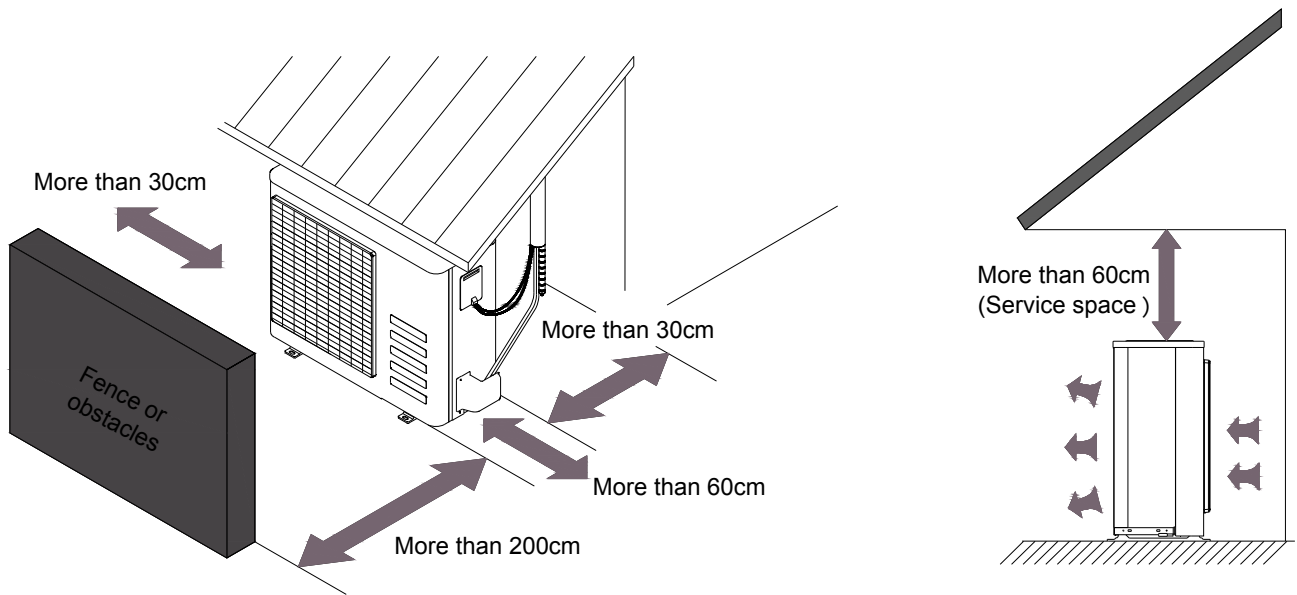

For MOAB02-07HN1, MOAB02-09HN1,

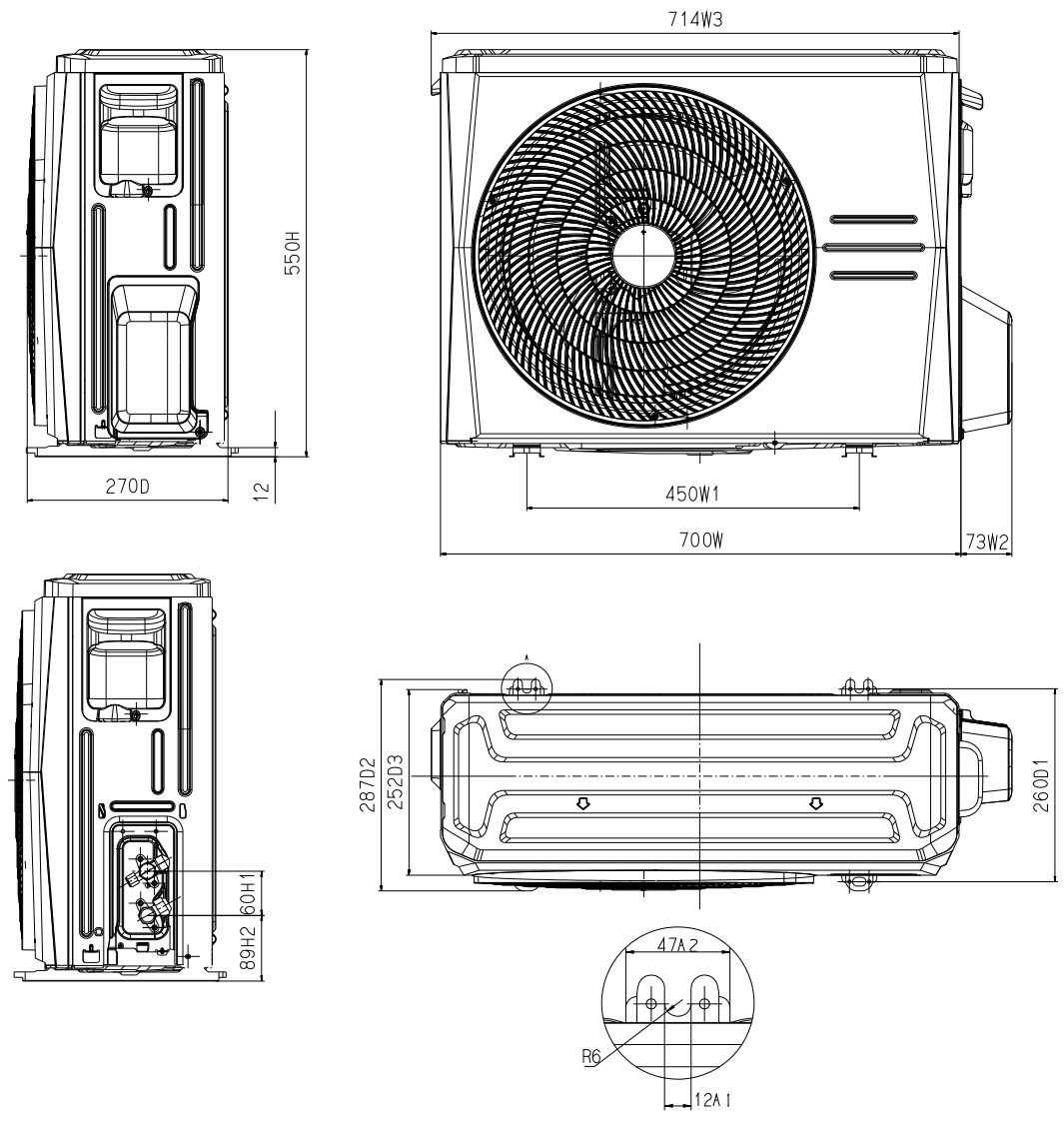

For MOBA01-12HN1, MOBA03-18HN1,

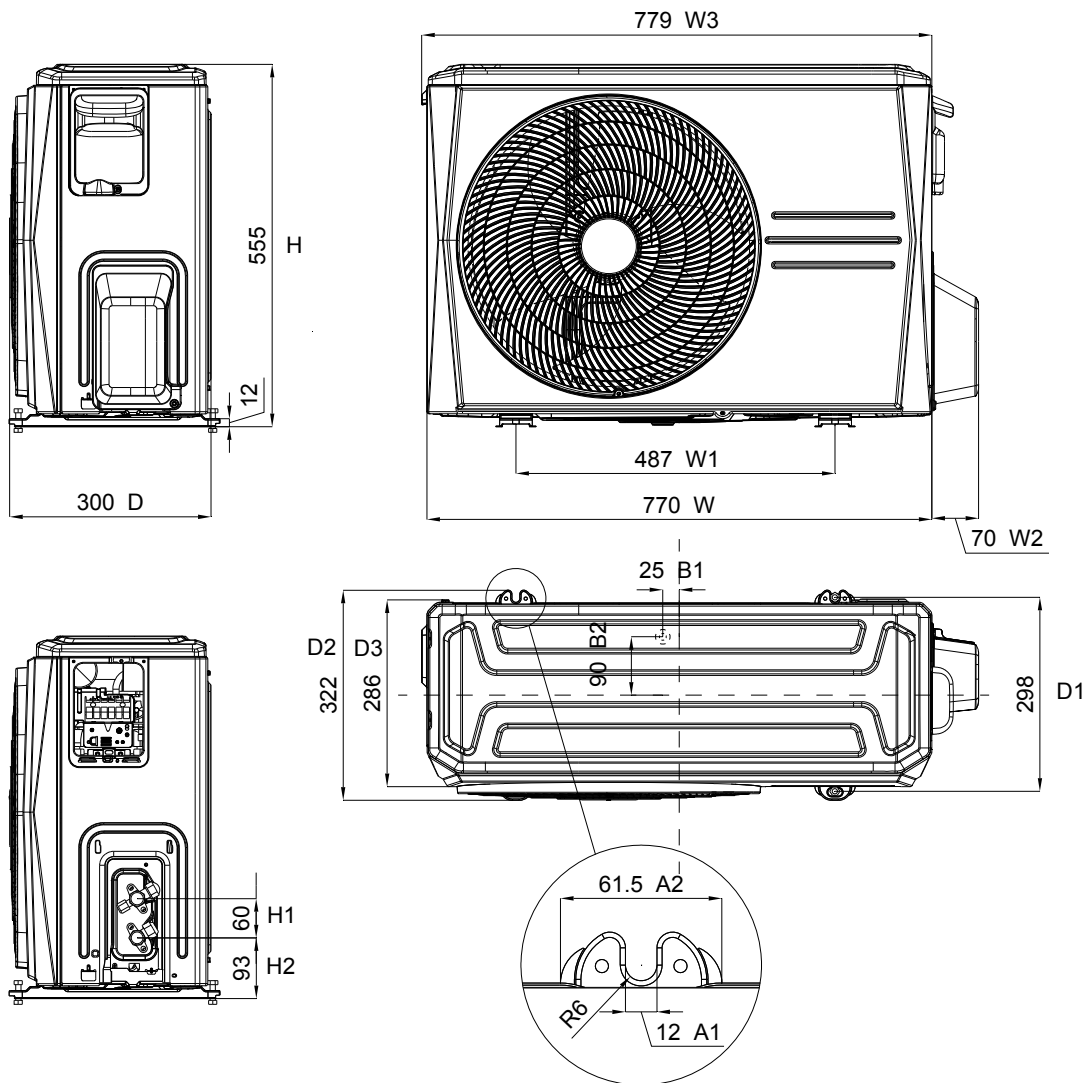

For MOCA02-24HN1,

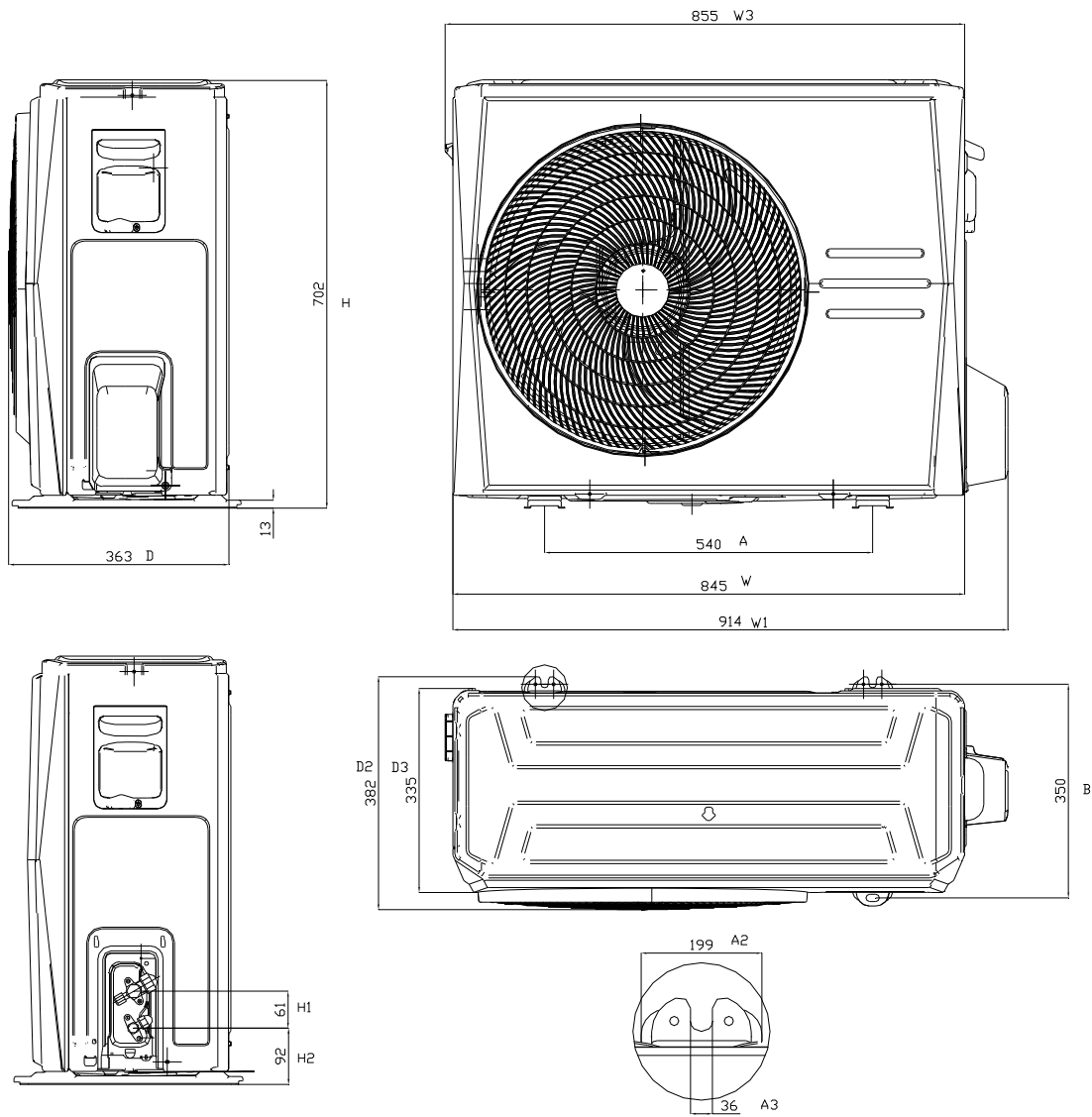

5. Capacity tables

MSMA1A-07HRN1 / MOAB02-07HN1

Cooling

COOLING		OUTDOOR TEMPERATURE DRY					
Indoor Conditions		21°C	25°C	30°C	35°C	40°C	45°C
21°C D 15°C W	Total capacity kW	1,90	1,88	1,86	1,82	1,46	1,37
	Sensitive capacity kW	1,52	1,50	1,49	1,46	1,17	1,09
	Input kW.	2,05	2,03	2,02	1,98	2,04	2,12
24°C D 17°C W	Total capacity kW	1,94	1,92	1,90	1,87	1,49	1,40
	Sensitive capacity kW	1,55	1,54	1,52	1,49	1,19	1,12
	Input kW.	0,65	0,64	0,64	0,62	0,64	0,67
27°C D 19°C W	Total capacity kW	2,13	2,11	2,09	2,05	1,64	1,54
	Sensitive capacity kW	1,71	1,69	1,67	1,64	1,31	1,23
	Input kW.	0,66	0,66	0,65	0,64	0,66	0,68
32°C D 23°C W	Total capacity kW	2,39	2,36	2,34	2,30	1,84	1,72
	Sensitive capacity kW	1,91	1,89	1,87	1,84	1,47	1,38
	Input kW.	0,74	0,74	0,73	0,72	0,74	0,77

Heating

HEATING		OUTDOOR CONDITIONS						
Indoor Conditions		24°C D 18°C W	12°C D 11°C W	7°C D 6°C W	4°C D 3°C W	0°C D -1°C W	-5°C D -6°C W	-7°C D -8°C W
15°C	Capacity kW	3,00	2,97	2,60	2,13	1,82	1,43	1,32
	Input kW.	0,83	0,82	0,72	0,67	0,65	0,57	0,56
18°C	Capacity kW	2,86	2,83	2,48	2,03	1,74	1,36	1,27
	Input kW.	0,79	0,79	0,69	0,64	0,62	0,55	0,53
20°C	Capacity kW	2,70	2,67	2,34	1,92	1,64	1,29	1,19
	Input kW.	0,75	0,74	0,65	0,60	0,59	0,52	0,50
22°C	Capacity kW	2,30	2,27	1,99	1,63	1,39	1,09	1,01
	Input kW.	0,69	0,68	0,60	0,55	0,54	0,48	0,46
27°C	Capacity kW	2,30	2,27	1,99	1,63	1,39	1,09	1,01
	Input kW.	0,70	0,69	0,61	0,56	0,55	0,48	0,47

MSMA1A-09HRN1 / MOAB02-09HN1**Cooling**

COOLING		OUTDOOR TEMPERATURE DRY					
Indoor Conditions		21°C	25°C	30°C	35°C	40°C	45°C
21°C D 15°C W	Total capacity kW	2,43	2,41	2,39	2,34	1,87	1,76
	Sensitive capacity kW	1,95	1,93	1,91	1,87	1,50	1,40
	Input kW.	2,63	2,61	2,59	2,54	2,61	2,72
24°C D 17°C W	Total capacity kW	2,49	2,47	2,44	2,39	1,91	1,79
	Sensitive capacity kW	1,99	1,97	1,95	1,91	1,53	1,44
	Input kW.	0,83	0,82	0,82	0,80	0,82	0,86
27°C D 19°C W	Total capacity kW	2,74	2,71	2,68	2,63	2,10	1,97
	Sensitive capacity kW	2,19	2,17	2,15	2,10	1,68	1,58
	Input kW.	0,85	0,84	0,84	0,82	0,84	0,88
32°C D 23°C W	Total capacity kW	3,06	3,03	3,00	2,95	2,36	2,21
	Sensitive capacity kW	2,45	2,43	2,40	2,36	1,89	1,77
	Input kW.	0,95	0,94	0,94	0,92	0,95	0,98

Heating

HEATING		OUTDOOR CONDITIONS						
Indoor Conditions		24°C D 18°C W	12°C D 11°C W	7°C D 6°C W	4°C D 3°C W	0°C D -1°C W	-5°C D -6°C W	-7°C D -8°C W
15°C	Capacity kW	3,56	3,52	3,09	2,53	2,16	1,70	1,57
	Input kW.	0,99	0,97	0,85	0,79	0,77	0,68	0,66
18°C	Capacity kW	3,40	3,37	2,95	2,42	2,06	1,62	1,50
	Input kW.	0,94	0,93	0,81	0,75	0,74	0,65	0,63
20°C	Capacity kW	3,21	3,17	2,78	2,28	1,95	1,53	1,42
	Input kW.	0,89	0,88	0,77	0,71	0,70	0,61	0,60
22°C	Capacity kW	2,73	2,70	2,36	1,94	1,65	1,30	1,21
	Input kW.	0,82	0,81	0,71	0,66	0,64	0,57	0,55
27°C	Capacity kW	2,73	2,70	2,36	1,94	1,65	1,30	1,21
	Input kW.	0,83	0,82	0,72	0,66	0,65	0,57	0,56

MSMA1B-12HRN1 / MOBA01-12HN1**Cooling**

Indoor Conditions		21°C	25°C	30°C	35°C	40°C	45°C
21°C D 15°C W	Total capacity kW	3,25	3,22	3,19	3,12	2,50	2,34
	Sensitive capacity kW	2,60	2,57	2,55	2,50	2,00	1,87
	Input kW.	3,51	3,48	3,45	3,39	3,49	3,62
24°C D 17°C W	Total capacity kW	3,32	3,29	3,26	3,19	2,56	2,40
	Sensitive capacity kW	2,66	2,63	2,61	2,56	2,04	1,92
	Input kW.	1,10	1,09	1,08	1,06	1,10	1,14
27°C D 19°C W	Total capacity kW	3,65	3,62	3,58	3,51	2,81	2,63
	Sensitive capacity kW	2,92	2,89	2,86	2,81	2,25	2,11
	Input kW.	1,13	1,12	1,11	1,09	1,12	1,17
32°C D 23°C W	Total capacity kW	4,09	4,05	4,01	3,93	3,14	2,95
	Sensitive capacity kW	3,27	3,24	3,21	3,14	2,52	2,36
	Input kW.	1,26	1,25	1,25	1,22	1,26	1,31

Heating

HEATING		OUTDOOR CONDITIONS						
Indoor Conditions		24°C D 18°C W	12°C D 11°C W	7°C D 6°C W	4°C D 3°C W	0°C D -1°C W	-5°C D -6°C W	-7°C D -8°C W
15°C	Capacity kW	4,50	4,45	3,90	3,19	2,73	2,14	1,99
	Input kW.	1,24	1,23	1,07	1,00	0,97	0,86	0,83
18°C	Capacity kW	4,30	4,25	3,72	3,05	2,60	2,05	1,90
	Input kW.	1,19	1,17	1,03	0,95	0,93	0,82	0,80
20°C	Capacity kW	4,05	4,01	3,51	2,88	2,46	1,93	1,79
	Input kW.	1,12	1,11	0,97	0,90	0,88	0,77	0,75
22°C	Capacity kW	3,45	3,41	2,98	2,45	2,09	1,64	1,52
	Input kW.	1,03	1,02	0,89	0,83	0,81	0,71	0,69
27°C	Capacity kW	3,45	3,41	2,98	2,45	2,09	1,64	1,52
	Input kW.	1,04	1,03	0,90	0,84	0,82	0,72	0,70

MSMA1C-18HRN1 / MOBA03-18HN1**Cooling**

COOLING		OUTDOOR TEMPERATURE DRY					
Indoor Conditions		21°C	25°C	30°C	35°C	40°C	45°C
21°C D 15°C W	Total capacity kW	4,88	4,83	4,78	4,69	3,75	3,52
	Sensitive capacity kW	3,90	3,86	3,83	3,75	3,00	2,81
	Input kW.	5,26	5,23	5,19	5,09	5,24	5,44
24°C D 17°C W	Total capacity kW	4,99	4,94	4,89	4,80	3,84	3,60
	Sensitive capacity kW	3,99	3,95	3,91	3,84	3,07	2,88
	Input kW.	1,62	1,60	1,59	1,56	1,61	1,67
27°C D 19°C W	Total capacity kW	5,48	5,43	5,38	5,27	4,22	3,95
	Sensitive capacity kW	4,38	4,34	4,30	4,22	3,37	3,16
	Input kW.	1,66	1,64	1,63	1,60	1,65	1,71
32°C D 23°C W	Total capacity kW	6,14	6,08	6,02	5,90	4,72	4,43
	Sensitive capacity kW	4,91	4,86	4,82	4,72	3,78	3,54
	Input kW.	1,85	1,84	1,83	1,79	1,85	1,92

Heating

HEATING		OUTDOOR CONDITIONS						
Indoor Conditions		24°C D 18°C W	12°C D 11°C W	7°C D 6°C W	4°C D 3°C W	0°C D -1°C W	-5°C D -6°C W	-7°C D -8°C W
15°C	Capacity kW	7,13	7,05	6,17	5,06	4,32	3,39	3,15
	Input kW.	1,97	1,95	1,71	1,58	1,54	1,36	1,32
18°C	Capacity kW	6,81	6,73	5,89	4,83	4,13	3,24	3,01
	Input kW.	1,88	1,86	1,63	1,51	1,47	1,30	1,26
20°C	Capacity kW	6,42	6,35	5,56	4,56	3,89	3,06	2,84
	Input kW.	1,78	1,76	1,54	1,43	1,39	1,23	1,19
22°C	Capacity kW	5,46	5,40	4,73	3,88	3,31	2,60	2,41
	Input kW.	1,64	1,62	1,42	1,31	1,28	1,13	1,10
27°C	Capacity kW	5,46	5,40	4,73	3,88	3,31	2,60	2,41
	Input kW.	1,66	1,64	1,43	1,33	1,29	1,14	1,11

MSMA1D-24HRN1 / MOCA02-24HN1**Cooling**

COOLING		OUTDOOR TEMPERATURE DRY					
Indoor Conditions		21°C	25°C	30°C	35°C	40°C	45°C
21°C D 15°C W	Total capacity kW	6,51	6,44	6,38	6,26	5,01	4,69
	Sensitive capacity kW	5,21	5,16	5,11	5,01	4,00	3,75
	Input kW.	7,02	6,97	6,92	6,78	6,99	7,26
24°C D 17°C W	Total capacity kW	6,65	6,59	6,53	6,40	5,12	4,80
	Sensitive capacity kW	5,32	5,27	5,22	5,12	4,09	3,84
	Input kW.	2,52	2,51	2,49	2,44	2,51	2,61
27°C D 19°C W	Total capacity kW	7,31	7,24	7,17	7,03	5,62	5,27
	Sensitive capacity kW	5,85	5,79	5,74	5,62	4,50	4,22
	Input kW.	2,59	2,57	2,55	2,50	2,58	2,68
32°C D 23°C W	Total capacity kW	8,19	8,11	8,03	7,87	6,30	5,91
	Sensitive capacity kW	6,55	6,49	6,42	6,30	5,04	4,72
	Input kW.	2,90	2,88	2,86	2,80	2,88	3,00

Heating

HEATING		OUTDOOR CONDITIONS						
Indoor Conditions		24°C D 18°C W	12°C D 11°C W	7°C D 6°C W	4°C D 3°C W	0°C D -1°C W	-5°C D -6°C W	-7°C D -8°C W
15°C	Capacity kW	9,01	8,91	7,80	6,40	5,46	4,29	3,98
	Input kW.	2,80	2,77	2,43	2,25	2,19	1,93	1,88
18°C	Capacity kW	8,61	8,51	7,45	6,11	5,22	4,10	3,80
	Input kW.	2,68	2,65	2,32	2,15	2,09	1,84	1,80
20°C	Capacity kW	8,12	8,03	7,03	5,76	4,92	3,87	3,59
	Input kW.	2,53	2,50	2,19	2,03	1,98	1,74	1,70
22°C	Capacity kW	6,90	6,82	5,98	4,90	4,18	3,29	3,05
	Input kW.	2,33	2,31	2,02	1,87	1,82	1,61	1,56
27°C	Capacity kW	6,90	6,82	5,98	4,90	4,18	3,29	3,05
	Input kW.	2,35	2,33	2,04	1,89	1,84	1,62	1,58

6. Refrigerant Cycle Diagram

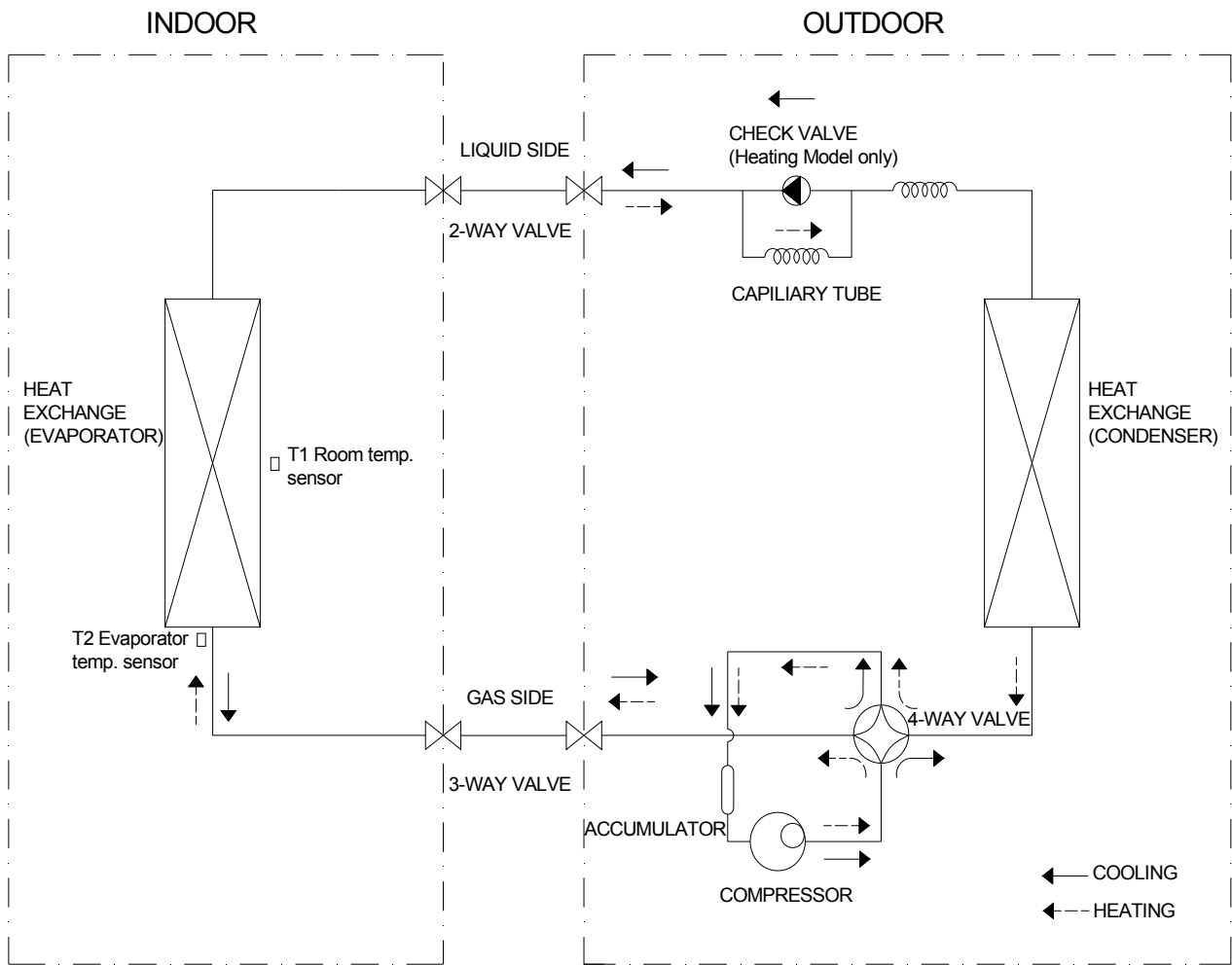

7. Installation Details

7.1 Wrench torque sheet for installation

Outside diameter		Torque	Additional tightening torque
mm	inch	N.cm	N.cm
Φ6.35	1/4	1500(153kgf.cm)	1600(163kgf.cm)
Φ9.52	3/8	2500(255kgf.cm)	2600(265kgf.cm)
Φ12.7	1/2	3500(357kgf.cm)	3600(367kgf.cm)
Φ15.9	5/8	4500(459kgf.cm)	4700(479kgf.cm)
Φ19	3/4	6500(663kgf.cm)	6700(683kgf.cm)

7.2 Connecting the cables

The power cord of connect should be selected according to the following specifications sheet.

Rated current of appliance	Nominal cross-sectional area (mm ²)
>3 and ≤6	0.75
>6 and ≤10	1
>10 and ≤16	1.5
>16 and ≤25	2.5
>25 and ≤32	4

The cable size and the current of the fuse or switch are determined by the maximum current indicated on the nameplate which located on the side panel of the unit. Please refer to the nameplate before selecting the cable, fuse and switch.

7.3 Pipe length and the elevation

The pipe length and refrigerant amount:

Model	Pipe size		Standard length (m)	Max. Elevation B (m)	Max. Length A (m)	Additional refrigerant (g/m)
	Gas	Liquid				
MSMAA-07HRN1-QC2+ MOAB02-07HN1-QC2	3/8" (Φ9.52)	1/4" (Φ6.35)	5	8	20	20
MSMAA-09HRN1-QC2+ MOAB02-09HN1-QC2	3/8" (Φ9.52)	1/4" (Φ6.35)	5	8	20	20
MSMAB-12HRN1-QC2+ MOBA01-12HN1-QC2	1/2" (Φ12.7)	1/4" (Φ6.35)	5	8	20	20
MSMAC-18HRN1-QC2+ MOBA03-18HN1-QC2	1/2" (Φ12.7)	1/4" (Φ6.35)	5	10	25	20
MSMAD-24HRN1-QB8W+ MOCA02-24HN1-QB8W	5/8" (Φ15.9)	3/8" (Φ9.52)	5	10	25	40

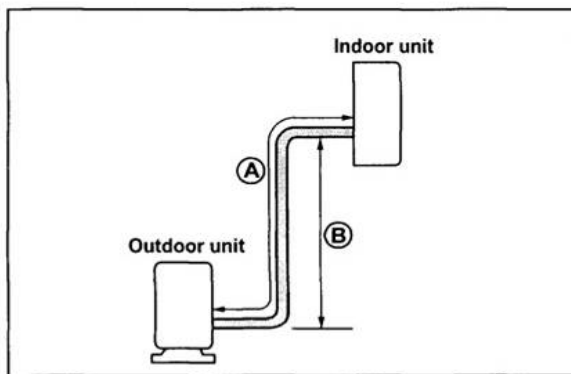

Caution:

The capacity test is based on the standard length and the maximum permissible length is based on the system reliability.

7.4 Installation for the first time

Air and moisture in the refrigerant system have undesirable effects as below:

- Pressure in the system rises.
- Operating current rises.
- Cooling or heating efficiency drops.
- Moisture in the refrigerant circuit may freeze and block capillary tubing.
- Water may lead to corrosion of parts in the refrigerant system.

Therefore, the indoor units and the pipes between indoor and outdoor units must be leak tested and evacuated to remove gas and moisture from the system.

Gas leak check (Soap water method):

Apply soap water or a liquid neutral detergent on the indoor unit connections or outdoor unit connections by a soft brush to check for leakage of the connecting points of the piping. If bubbles come out, the pipes have leakage.

1. Air purging with vacuum pump

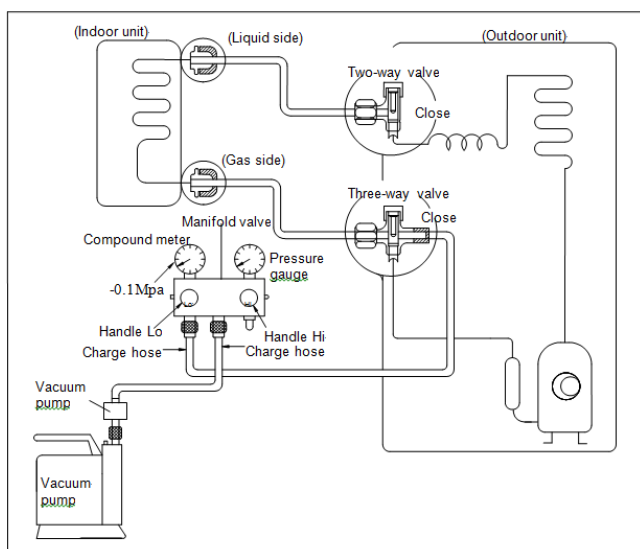

- 1) Completely tighten the flare nuts of the indoor and outdoor units, confirm that both the 2-way and 3-way valves are set to the closed position.
- 2) Connect the charge hose with the push pin of handle lo to the 3-way valves gas service port.
- 3) Connect the charge hose of handle hi connection to the vacuum pump.
- 4) Fully open the handle Lo of the manifold valve.
- 5) Operate the vacuum pump to evacuate.
- 6) Make evacuation for 30 minutes and check whether the compound meter indicates -0.1Mpa. If the meter does not indicate -0.1Mpa after pumping 30 minutes, it should be pumped 20 minutes more. If the pressure can't achieve -0.1Mpa after pumping 50 minutes, please check if there are some leakage points.

Fully close the handle Lo valve of the manifold valve and stop the operation of the vacuum pump. Confirm that the gauge needle does not move (approximately 5 minutes after turning off the vacuum pump).

- 7) Turn the flare nut of the 3-way valves about 45° counterclockwise for 6 or 7seconds after the gas coming out, then tighten the flare nut again. Make sure the pressure display in the pressure indicator is a little higher than the atmosphere pressure. Then remove the charge hose from the 3 way valve.
- 8) Fully open the 2 way valve and 3 way valve and securely tighten the cap of the 3 way valve.

2. Air purging by refrigerant

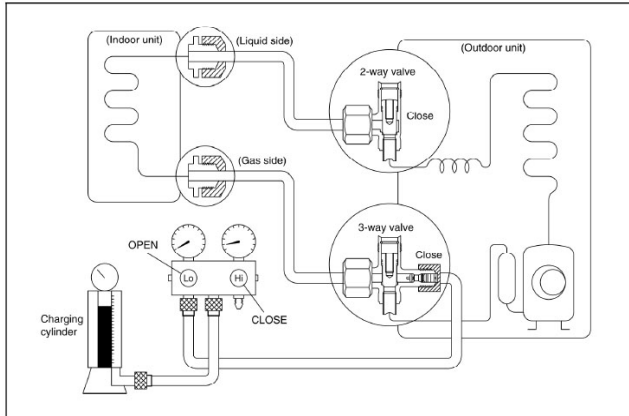

Procedure:

- 1). Confirm that both the 2-way and 3-way valves are set to the closed position.
- 2). Connect the charge set and a charging cylinder to the service port of the 3-way valve.
- 3). Air purging.
Open the valves on the charging cylinder and the charge set. Purge the air by loosening the flare nut on the 2-way valve approximately 45° for 3 seconds then closing it for 1 minute; repeat 3 times.
After purging the air, use a torque wrench to tighten the flare nut on the 2-way valve.
- 4). Check the gas leakage.
Check the flare connections for gas leakage.
- 5). Discharge the refrigerant.
Close the valve on the charging cylinder and discharge the refrigerant by loosening the flare nut on the 2-way valve approximately 45° until the gauge indicates 0.3 to 0.5 Mpa.
- 6). Disconnect the charge set and the charging cylinder, and set the 2-way and 3-way valves to the open position.
Be sure to use a hexagonal wrench to operate the valve stems.
- 7). Mount the valve stems nuts and the service port cap.
Be sure to use a torque wrench to tighten the service port cap to a torque 18N·m.
Be sure to check the gas leakage.

3. Adding the refrigerant if the pipe length >5m

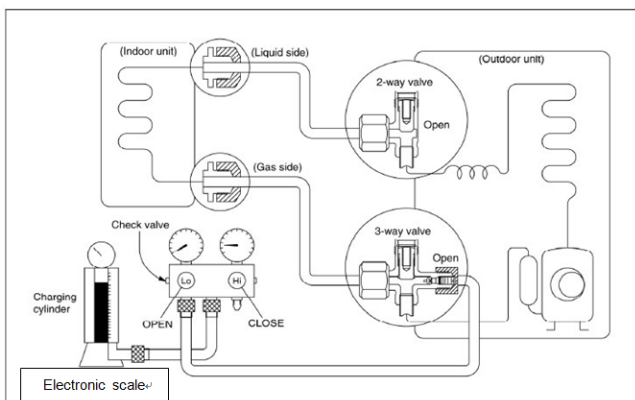

Procedure:

- 1). Connect the charge hose to the charging cylinder, open the 2-way valve and the 3-way valve.
Connect the charge hose which you disconnected from the vacuum pump to the valve at the bottom of the cylinder. If the refrigerant is R410A, make the cylinder bottom up to ensure the liquid charge.
- 2). Purge the air from the charge hose.

Open the valve at the bottom of the cylinder and press the check valve on the charge set to purge the air (be careful of the liquid refrigerant).

3) Put the charging cylinder onto the electronic scale and record the weight.

4) Operate the air conditioner at the cooling mode.

5) Open the valves (Low side) on the charge set and charge the system with liquid refrigerant.

6).When the electronic scale displays the proper weight (refer to the table), disconnect the charge hose from the 3-way valve's service port immediately and turn off the air conditioner before disconnecting the hose.

7). Mount the valve stem caps and the service port

Use torque wrench to tighten the service port cap to a torque of 18N.m.

Be sure to check for gas leakage.

7.5 Adding the refrigerant after running the system for many years

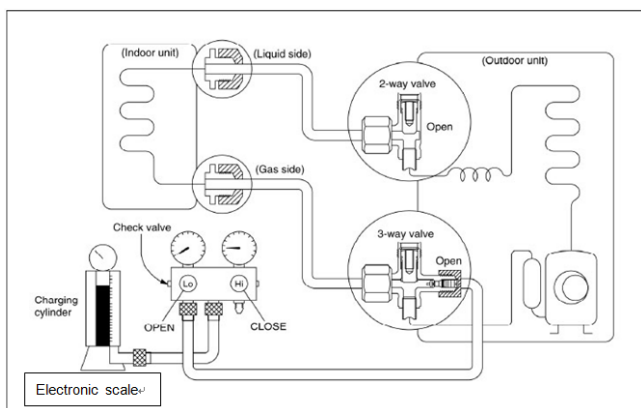

Procedure:

1). Connect the charge hose to the 3-way service port, open the 2-way valve and the 3-way valve.

Connect the charge hose to the valve at the bottom of the cylinder. If the refrigerant is R410A, make the cylinder bottom up to ensure liquid charge.

2). Purge the air from the charge hose.

Open the valve at the bottom of the cylinder and press the check valve on the charge set to purge the air (be careful of the liquid refrigerant).

3) Put the charging cylinder onto the electronic scale and record the weight.

4) Operate the air conditioner at the cooling mode.

5) Open the valves (Low side) on the charge set and charge the system with liquid refrigerant.

6).When the electronic scale displays the proper weight (refer to the gauge and the pressure of the low side), disconnect the charge hose from the 3-way valve's service port immediately and turn off the air conditioner before disconnecting the hose.

7). Mount the valve stem caps and the service port

Use torque wrench to tighten the service port cap to a torque of 18N.m.

Be sure to check for gas leakage.

7.6 Re-installation while the indoor unit need to be repaired

1. Collecting the refrigerant into the outdoor unit

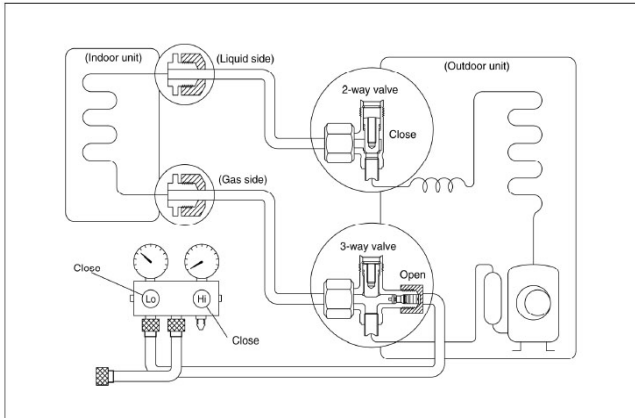

Procedure

- 1). Confirm that both the 2-way and 3-way valves are set to the opened position
Remove the valve stem caps and confirm that the valve stems are in the opened position.
Be sure to use a hexagonal wrench to operate the valve stems.
- 2). Connect the charge hose with the push pin of handle lo to the 3-way valves gas service port.
- 3). Air purging of the charge hose.
Open the handle Lo valve of the manifold valve slightly to purge air from the charge hose for 5 seconds and then close it quickly.
- 4). Set the 2-way valve to the close position.
- 5). Operate the air conditioner at the cooling cycle and stop it when the gauge indicates 0.1MPa.
- 6). Set the 3-way valve to the closed position immediately
Do this quickly so that the gauge ends up indicating 0.3 to 0.5Mpa.
Disconnect the charge set, and tighten the 2-way and 3-way valve's stem nuts.
Use a torque wrench to tighten the 3-way valves service port cap to a torque of 18N.m.
Be sure to check for gas leakage.

2. Air purging by the refrigerant

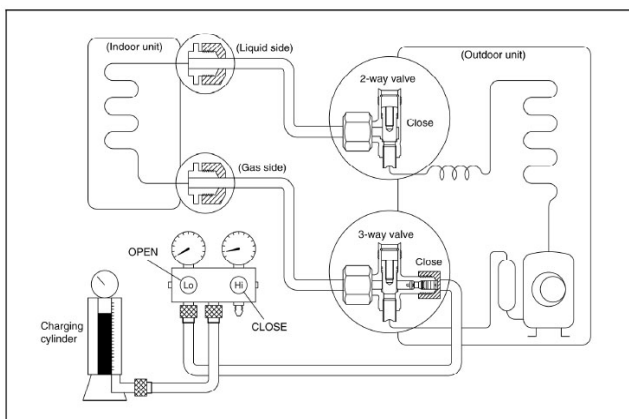

Procedure:

- 1). Confirm that both the 2-way and 3-way valves are set to the closed position.
- 2). Connect the charge set and a charging cylinder to the service port of the 3-way valve
Leave the valve on the charging cylinder closed.
- 3). Air purging.

Open the valves on the charging cylinder and the charge set. Purge the air by loosening the flare nut on

the 2-way valve approximately 45° for 3 seconds then closing it for 1 minute; repeat 3 times.

After purging the air, use a torque wrench to tighten the flare nut on the 2-way valve.

4). Check the gas leakage

Check the flare connections for gas leakage.

5). Discharge the refrigerant.

Close the valve on the charging cylinder and discharge the refrigerant by loosening the flare nut on the 2-way valve approximately 45° until the gauge indicates 0.3 to 0.5 Mpa.

6). Disconnect the charge set and the charging cylinder, and set the 2-way and 3-way valves to the open position

Be sure to use a hexagonal wrench to operate the valve stems.

7). Mount the valve stems nuts and the service port cap

Be sure to use a torque wrench to tighten the service port cap to a torque 18N.m.

Be sure to check the gas leakage.

7.7 Re-installation while the outdoor unit need to be repaired

1. Evacuation for the whole system

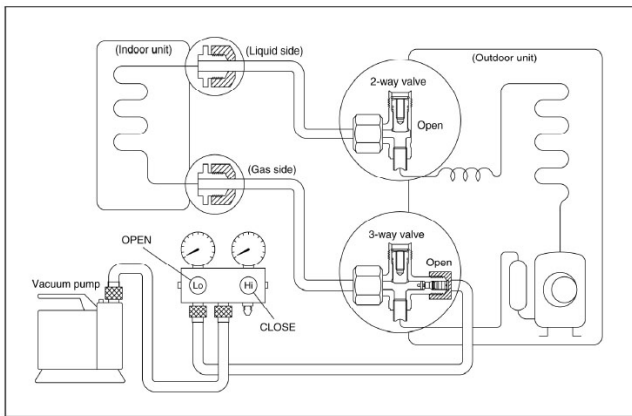

Procedure:

- 1). Confirm that both the 2-way and 3-way valves are set to the opened position.
- 2). Connect the vacuum pump to 3-way valve's service port.
- 3). Evacuation for approximately one hour. Confirm that the compound meter indicates -0.1Mpa.
- 4). Close the valve (Low side) on the charge set, turn off the vacuum pump, and confirm that the gauge needle does not move (approximately 5 minutes after turning off the vacuum pump).
- 5). Disconnect the charge hose from the vacuum pump.

2. Refrigerant charging

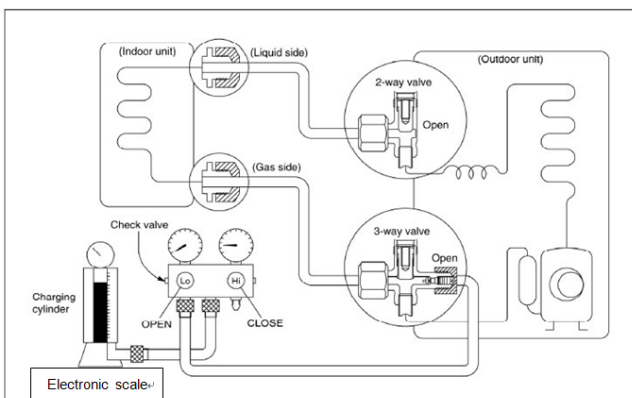

Procedure:

- 1). Connect the charge hose to the charging cylinder, open the 2-way valve and the 3-way valve
Connect the charge hose which you disconnected from the vacuum pump to the valve at the bottom of the cylinder. If the refrigerant is R410A, make the cylinder bottom up to ensure liquid charge.
- 2). Purge the air from the charge hose
Open the valve at the bottom of the cylinder and press the check valve on the charge set to purge the air (be careful of the liquid refrigerant).
- 3) Put the charging cylinder onto the electronic scale and record the weight.
- 4). Open the valves (Low side) on the charge set and charge the system with liquid refrigerant
If the system cannot be charge with the specified amount of refrigerant, or can be charged with a little at a time (approximately 150g each time) , operating the air conditioner in the cooling cycle; however, one time is not sufficient, wait approximately 1 minute and then repeat the procedure.
- 5).When the electronic scale displays the proper weight, disconnect the charge hose from the 3-way valve's service port immediately
If the system has been charged with liquid refrigerant while operating the air conditioner, turn off the air conditioner before disconnecting the hose.
- 6). Mounted the valve stem caps and the service port
Use torque wrench to tighten the service port cap to a torque of 18N.m.
Be sure to check for gas leakage

8. Wiring Diagram

8.1 Indoor Unit

MSMA1A-07HRN1, MSMA1A-09HRN1, MSMA1B-12HRN1, MSMA1C-18HRN1

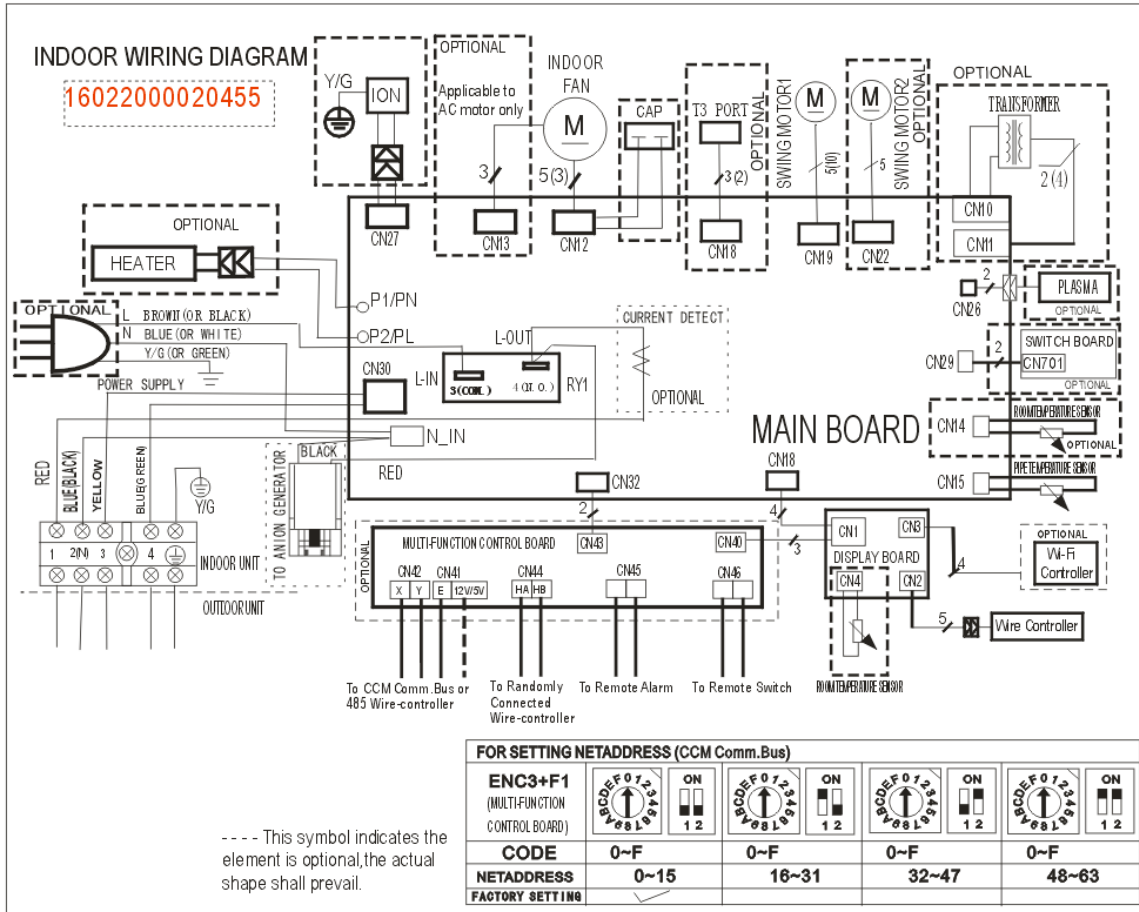

MSMA1D-24HRN1,

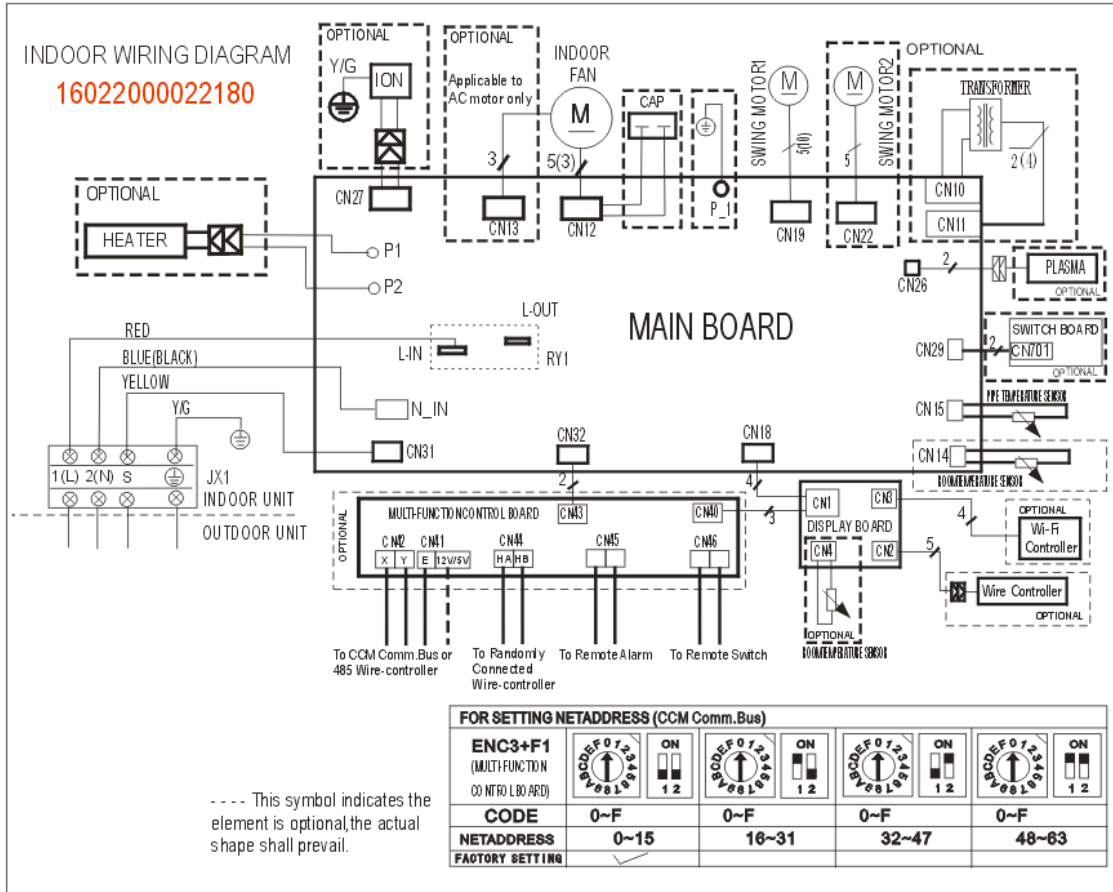

8.2 Outdoor Unit

MOAB02-07HN1, MOAB02-09HN1, MOBA01-12HN1, MOBA03-18HN1,

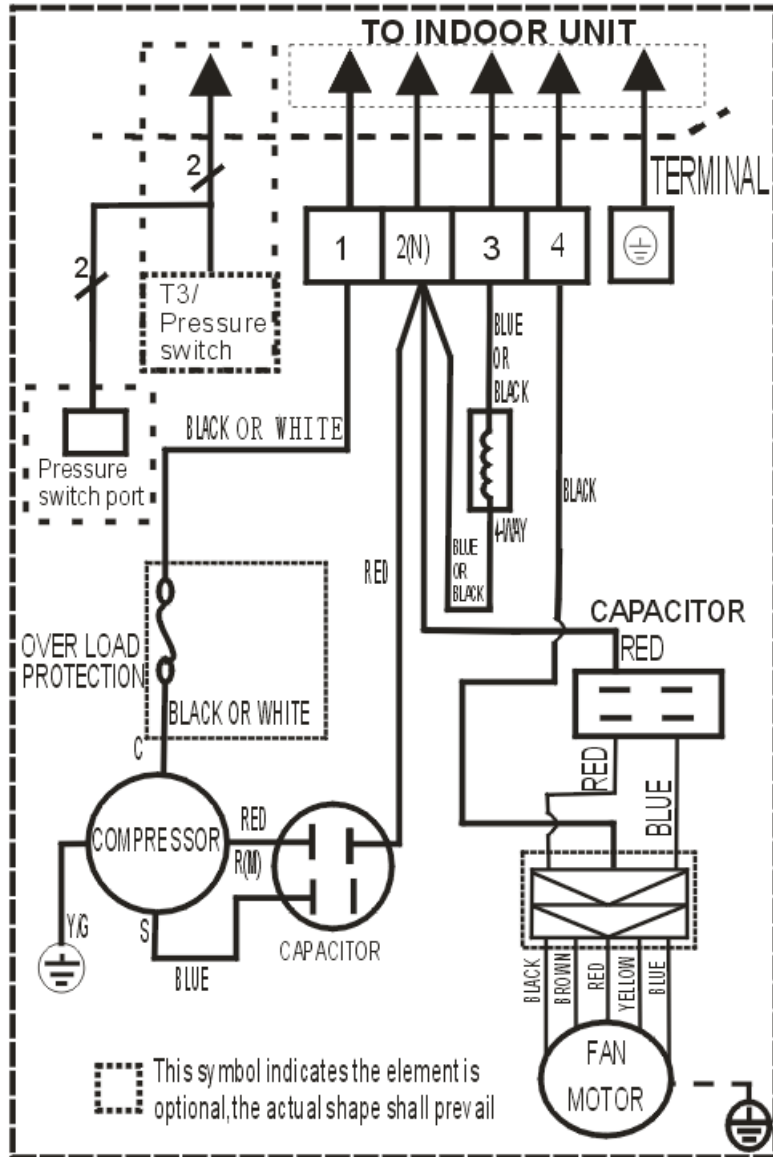

MOCA02-24HN1

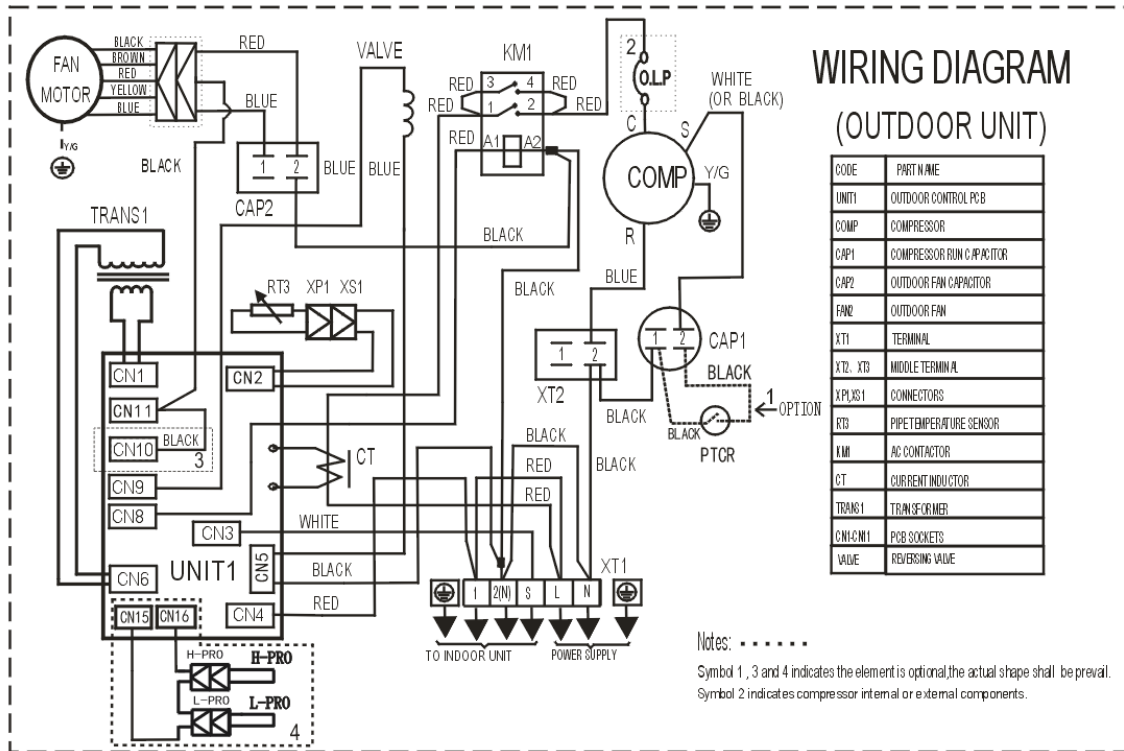

9. Operation Characteristics

Mode	Cooling operation	Heating operation	Drying operation
Temperature			
Room temperature	17°C~32°C	0°C~30°C	10°C~32°C
Outdoor temperature	18°C~43°C	-7°C~24°C	11°C~43°C

CAUTION:

1. If the air conditioner is used beyond the above conditions, certain safety protection features may come into operation and cause the unit to operate abnormally.

2. The room relative humidity should be less than 80%. If the air conditioner operates beyond this figure, the surface of the air conditioner may attract condensation. Please set the vertical air flow louver to its maximum angle (vertically to the floor), and set HIGH fan mode.

3. The optimum performance will be achieved during this operating temperature zone.

10. Electronic function

10.1 Abbreviation

T1: Indoor room temperature

T2: Coil temperature of evaporator

T3: Coil temperature of condenser

T4: Outdoor ambient temperature

T5: Compressor discharge temperature

10.2 Display function

10.2.1 Icon explanation on indoor display board.



Digital display:

Displays the temperature settings when the air conditioner is operational.

Displays the room temperature in Fan and Drying mode.

Displays the self-diagnostic codes.

Displays 'ON' for three seconds when Timer ON, Fresh, Swing, Turbo or Silence feature is activated.

Displays 'OF' for three seconds when Timer OFF is set.

Displays 'DF' for three seconds when Fresh, Swing, Turbo or Silence feature is cancelled.

Displays 'dF' under defrosting operation.

Displays 'cF' when anti-cold air feature is activated under heating mode.

Displays 'SC' during self clean operation (if applicable).

Displays 'FP' under 8°C heating operation.



WiFi control display (optional)

Displays when the WiFi control feature is activated. (Not available when the unit does not have this function)

NOTE:

A guide on using the infrared remote is not included in this literature package.

10.3 Main Protection

10.3.1 Time Delay at restart for compressor.

Less than 1 minute delay for the 1st time start-up and 3 minutes delay for others.

10.3.2 Sensor protection at open circuit and breaking disconnection.

10.3.3 Zero crossing detection error protection

If AC can not detect zero crossing signal for 4 minutes or the zero crossing signal time interval is not correct, the unit will stop and the LED will display the failure. The correct zero crossing signal time interval should be between 6-13ms.

10.3.4 Fan Speed is out of control

When Indoor Fan Speed is too low(lower than 300RPM) lasting 2 minutes, the unit stops and LED displays failure information and can't returns to normal operation automatically.

10.3.5 Current protection

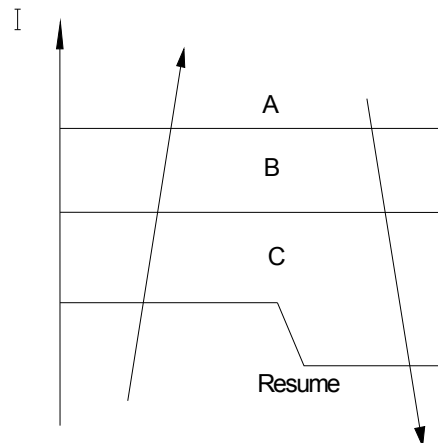

The current exceeds setting value for certain time, the compressor and outdoor fan will shut off.

10.3.6 Indoor fan delayed open function

When the unit starts up, the indoor fan will open 4s later. If the unit runs in heating mode, the indoor fan will be also controlled by anti-cold wind function.

10.3.7 Refrigerant leakage detection

This function is only active in cooling mode. It can better prevent the compressor being damaged by refrigerant leakage or compressor overload.

Open condition:

When compressor is active, the value of the Coil temperature of evaporator T2 has no change or very little change.

10.4 Operation Modes and Functions

10.4.1 Fan mode

- (1) Outdoor fan and compressor stop.
- (2) Temperature setting function is disabled, and no setting temperature is displayed.

- (3) Indoor fan can be set to high/med/low/auto.
 (4) The louver operates the same as in cooling mode.
 (5) Auto fan:

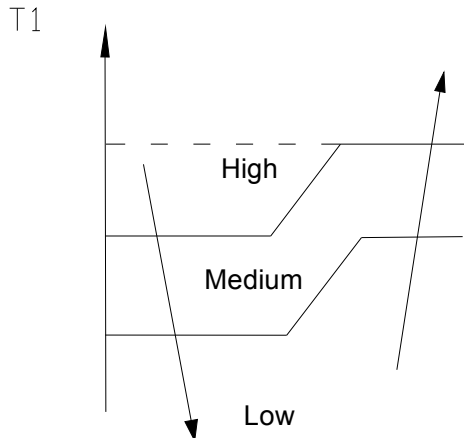

10.4.2 Cooling Mode

10.4.2.1 Compressor running rules

When indoor room temp. T1 is lower than setting value, the compressor and outdoor fan will shut off.

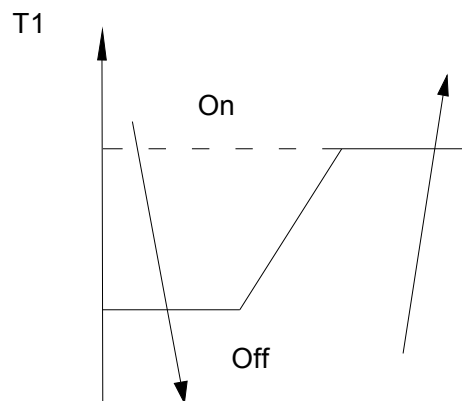

10.4.2.2 Outdoor fan running rules

The On-off outdoor units have single fan speed. The outdoor fan will run following the compressor except when AC is in evaporator high temp. protection in heating mode, condenser high temp. protection in cooling mode, defrosting mode and the current protection.

10.4.2.3 Indoor fan running rules

In cooling mode, indoor fan runs all the time and the speed can be selected as high, medium, low and auto.

The auto fan:

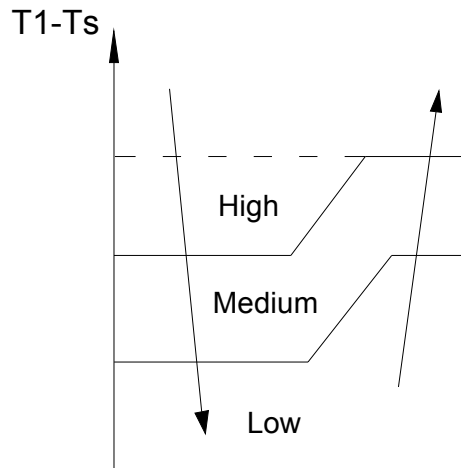

10.4.2.4 Low evaporator coil temperature T2 protection

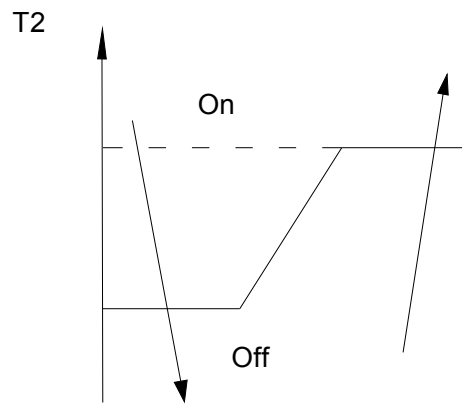

When the evaporator coil temp. T2 keeps lower than setting value, the compressor and outdoor fan will shut off.

10.4.2.5 High condenser temperature T3 protection (only for MSMAD-24HRN1-QB8W)

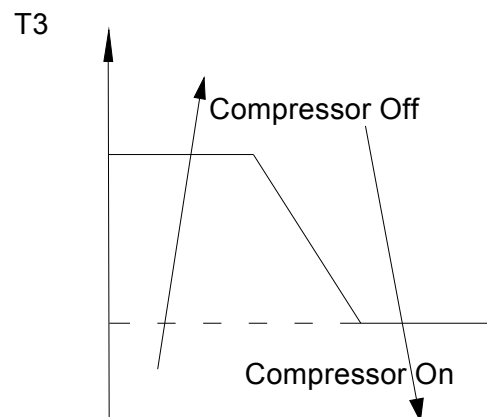

When high condenser temp. T3 is more than setting value, the compressor will stop. During the protection, the outdoor fan keeps working.

10.4.3 Heating Mode

10.4.3.1 Compressor running rules:

When indoor room temp. T_1 is higher than setting value the compressor and outdoor fan will shut off.

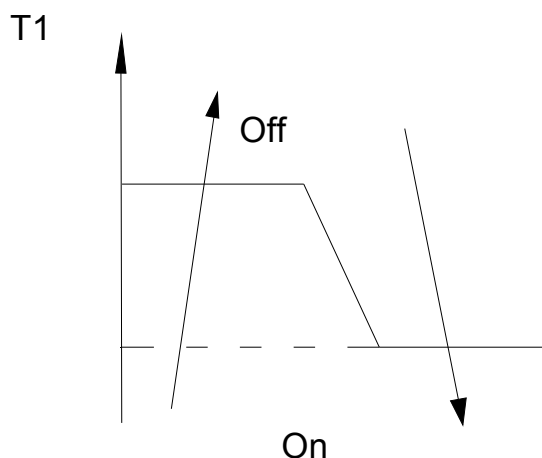

10.4.3.2 Outdoor fan running rules:

The outdoor units have single fan speed. The outdoor fan will run following the compressor except when AC is in evaporator high temp. protection in heating mode, condenser high temp. protection in cooling mode, defrosting mode and the current protection.

10.4.3.3 Indoor fan running rules:

When the compressor is on, the indoor fan can be set to high/med/low/auto. And the anti-cold wind function has the priority.

Auto fan action:

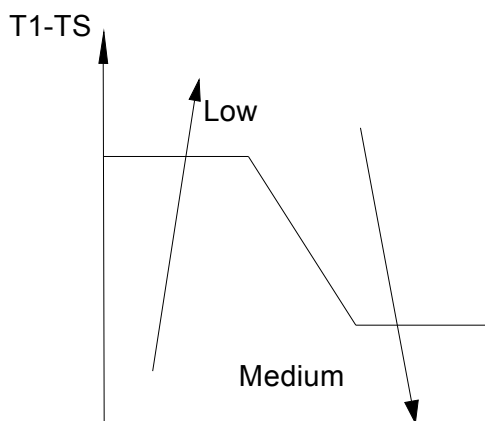

The indoor fan speed will adjust according to the value of $T_1 - T_S$.

10.4.3.4 Defrosting mode:

For MSMAA-07HRN1-QC2, MSMAA-09HRN1-QC2, MSMAB-12HRN1-QC2, MSMAC-18HRN1-QC2 models:

AC will enter the defrosting mode according to the value of temp difference between T_2 and T_1 , and also the compressor running time.

During the defrosting mode, the compressor keep running, indoor and outdoor motor will stop, defrost

lamp of the indoor unit will be lighted. "df" Will be displayed.

Condition of ending defrosting:

If any one of the following items is satisfied, the defrosting will terminate and the machine will turn to normal heating mode.

- (1) The defrosting time is reached to the setting value.
- (2) The defrosting has been running for 3 minutes and $T2 \geq TCDE1^{\circ}C$.
- (3) The defrosting has been running for 2 minutes, check the value of T2. If $T2 - T2_{min} \geq TCDE2^{\circ}C$ during 4 minutes, the defrosting will terminate.

For MSMAD-24HRN1-QB8W models:

AC will enter the defrosting mode according to the value of temp. of T3 and the value range of temp. change of T3 and also the compressor running time.

During the defrosting mode, the compressor keep running, indoor and outdoor motor will stop, defrost lamp of the indoor unit will be lighted. "DF" Will be displayed.

Condition of ending defrosting:

If any one of the following items is satisfied, the defrosting will terminate and the machine will turn to normal heating mode.

- (1) T3 rises to be higher than TC2.
- (2) The machine has run for 10 minutes in defrosting.

10.4.3.5 High evaporator coil temp.T2 protection:

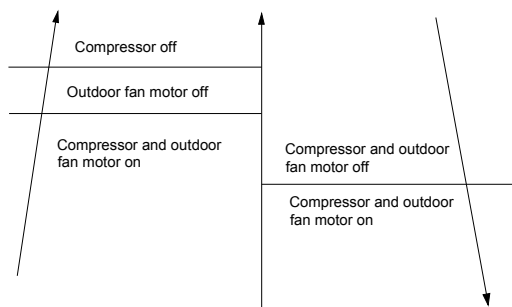

8.4.4 Auto-mode

This mode can be chosen with remote controller.

In auto mode, the machine will choose operation mode according to ΔT ($\Delta T = T1 - Ts$).

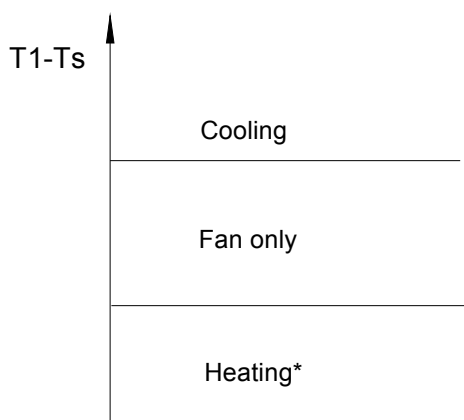

Heating*: For cooling only models, they will run at fan speed

AC will run in auto mode in the below cases:

- (1) Pressing the forced auto button.

- (2) If AC is off, it will run in auto mode when the timer on function is active.
- (3) After setting the mode, AC will run in auto mode if the compressor keeps not running for certain time.

10.4.5 Drying mode

8.4.5.1 The compressor is cycled running with 10 minutes on and then 5 minutes off. The indoor fan will keep running at low speed.

8.4.5.2 In drying mode, if room temperature is lower than 10°C, the compressor will stop and not resume until room temperature exceeds 13°C.

8.4.5.3 The evaporator anti-freezing protection is the same as that in cooling mode.

10.4.6 Forced operation function

Forced cooling mode:

The compressor and outdoor fan keep running and the indoor fan runs at low speed. After running for 30 minutes, AC will turn to auto mode with 24°C setting temperature.

Forced auto mode:

The action of forced auto mode is the same as normal auto mode with 24°C setting temperature.

When AC receives signals, such as switch on, switch off, timer on, timer off, mode setting, fan speed setting, sleeping mode setting, follow me setting, it will quit the forced operation.

10.4.7 Auto-Restart function

The indoor unit is equipped with auto-restart function, which is carried out through an auto-restart module. In case of a sudden power failure, the module memorizes the setting conditions before the power failure. The unit will resume the previous operation setting (not including swing function) automatically after 3 minutes when power returns.

If the memorization condition is forced cooling mode, the unit will run in cooling mode for 30 minutes and turn to auto mode as 24°C setting temp.

If AC is off before power off and AC is required to start up now, the compressor will have 1 minute delay when power on. Other conditions, the compressor will have 3 minutes delay when restarts.

10.4.8 Refrigerant Leakage Detection

With this new technology, the display area will show "EC" when the outdoor unit detects refrigerant leakage.

When compressor is active, the value of the Coil temperature of evaporator T2 has no change or very little change.

10.4.9 8°C Heating(optional)

When the compressor is running, the indoor fan motor will run without anti-cold air function.

When the compressor is off, the indoor fan motor is off .

10.4.10 Self clean (optional)

For heat pump models which are provided with this function, after running in cooling or drying mode, if the user press "Self Clean" button on remote controller, firstly, indoor unit runs in fan only mode for a while, then low heat operation and finally runs in fan only again. This function can keep the inside of indoor unit dry and prevent breeding of mold.

10.4.11 Follow me (optional)

- 1) If the indoor PCB receives the signal which results from pressing the FOLLOW ME button on remote controller, the buzzer will emit a sound and this indicates the follow me function is initiated. But when the indoor PCB receives signal which sent from remote controller every 3 minutes, the buzzer will not respond. When the unit is running with follow me function, the PCB will control the unit according to the temperature from follow me signal, and the temperature collection function of room temperature sensor will be shielded, but the error detective function of room temperature sensor will be still valid.
- 2) When the follow me function is available, the PCB will control the unit according to the room temperature from the remote controller and the setting temperature.
- 3) The PCB will take action to the mode change information from remote controller signal, but it will not affected by the setting temperature.
- 4) When the unit is running with follow me function, if the PCB doesn't receive any signal from remote controller for 7 minutes or pressing FOLLOW ME button again, the follow me function will be turned off automatically, and the temperature will control the unit according to the room temperature detected from its own room temperature sensor and setting temperature.

10.4.13 Point check function

Press the LED DISPLAY or LED or MUTE button of the remote controller three times, and then press the AIR DIRECTION or SWING button three times in ten seconds, the buzzer will keep ring for two seconds. The air conditioner will enter into the information enquiry status. You can press the LED DISPLAY or AIR DIRECTION button to check the next or front item's information within 27 seconds. When the AC enter the "information enquiry" status, it will display the code name in 2 seconds, the details are as follows.

Enquiry information	Displaying code	Meaning
T1	T1	T1 temp.
T2	T2	T2 temp.
T3	T3	T3 temp.
T4	T4	T4 temp.

When the AC enter into the information enquiry status, it will display the code value in the next 25s, the details are as follows.

Enquiry information	Display value	Meaning	Remark
T1,T2,T3,T4,	-14—70	-14—70	1. All the displaying temperature is actual value. 2. All the temperature is °C no matter what kind of remote controller is used. 3. If the actual value exceeds the range, it

			will display the maximum value or minimum value.
--	--	--	--

11. Troubleshooting

11.1 Indoor Unit Error Display

Operation lamp	Timer lamp	Display	LED STATUS
☆ 1 time	X	E0	EEPROM parameter error
☆ 2 times	X	E1	Indoor / outdoor units communication error(only for MSMAD-24HRN1-QB8W)
☆ 3 times	X	E2	Zero-crossing signal detection error
☆ 4 times	X	E3	Indoor fan speed has been out of control
☆ 5 times	X	E4	Indoor room temperature sensor T1 open circuit or short circuit
☆ 6 times	X	E5	Evaporator coil temperature sensor T2 open circuit or short circuit
☆ 9 times	X	E7	Indoor PCB /Display board communication error
☆ 7 times	X	EC	Refrigerant Leakage Detection
☆3 times	O	F2	Condenser coil temperature sensor T3 or T4 open circuit or short circuit(only for MSMAD-24HRN1-QB8W)

O (light)

X (off)

☆ (flash)

11.2 Trouble shooting

11.2.1 EEPROM parameter error diagnosis and solution (E0)

Error Code	E0
Malfunction decision conditions	Indoor or outdoor PCB main chip does not receive feedback from EEPROM chip.
Supposed causes	<ul style="list-style-type: none"> ● Installation mistake ● PCB faulty

Trouble shooting:

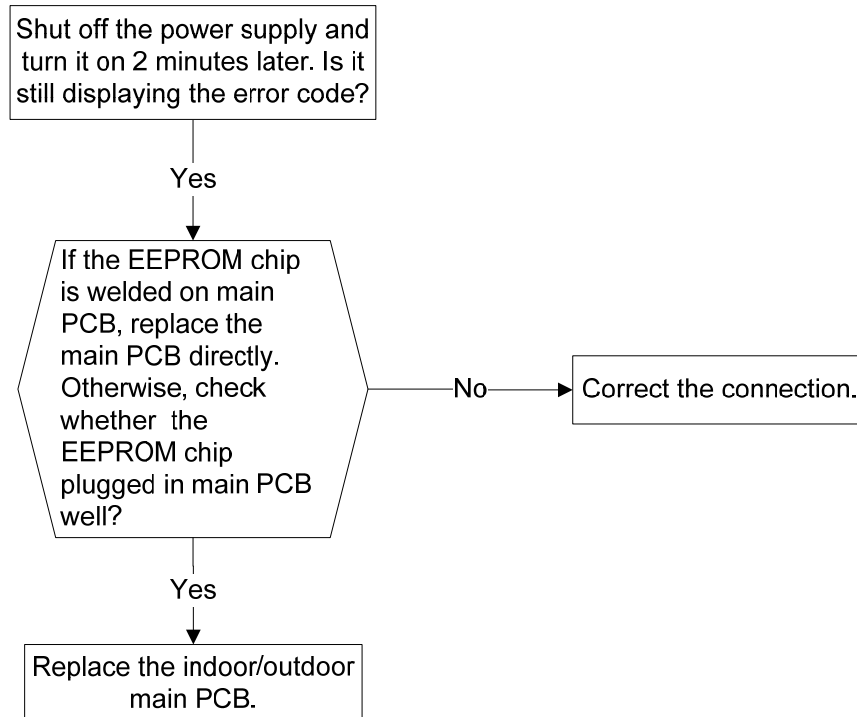

EEPROM: a read-only memory whose contents can be erased and reprogrammed using a pulsed voltage.

11.2.2 Indoor / outdoor unit's communication diagnosis and solution (E1)

Error Code	E1
Malfunction decision conditions	Indoor unit does not receive the feedback from outdoor unit during 120 seconds.
Supposed causes	<ul style="list-style-type: none"> ● Wiring mistake ● Indoor or outdoor PCB faulty

Trouble shooting:

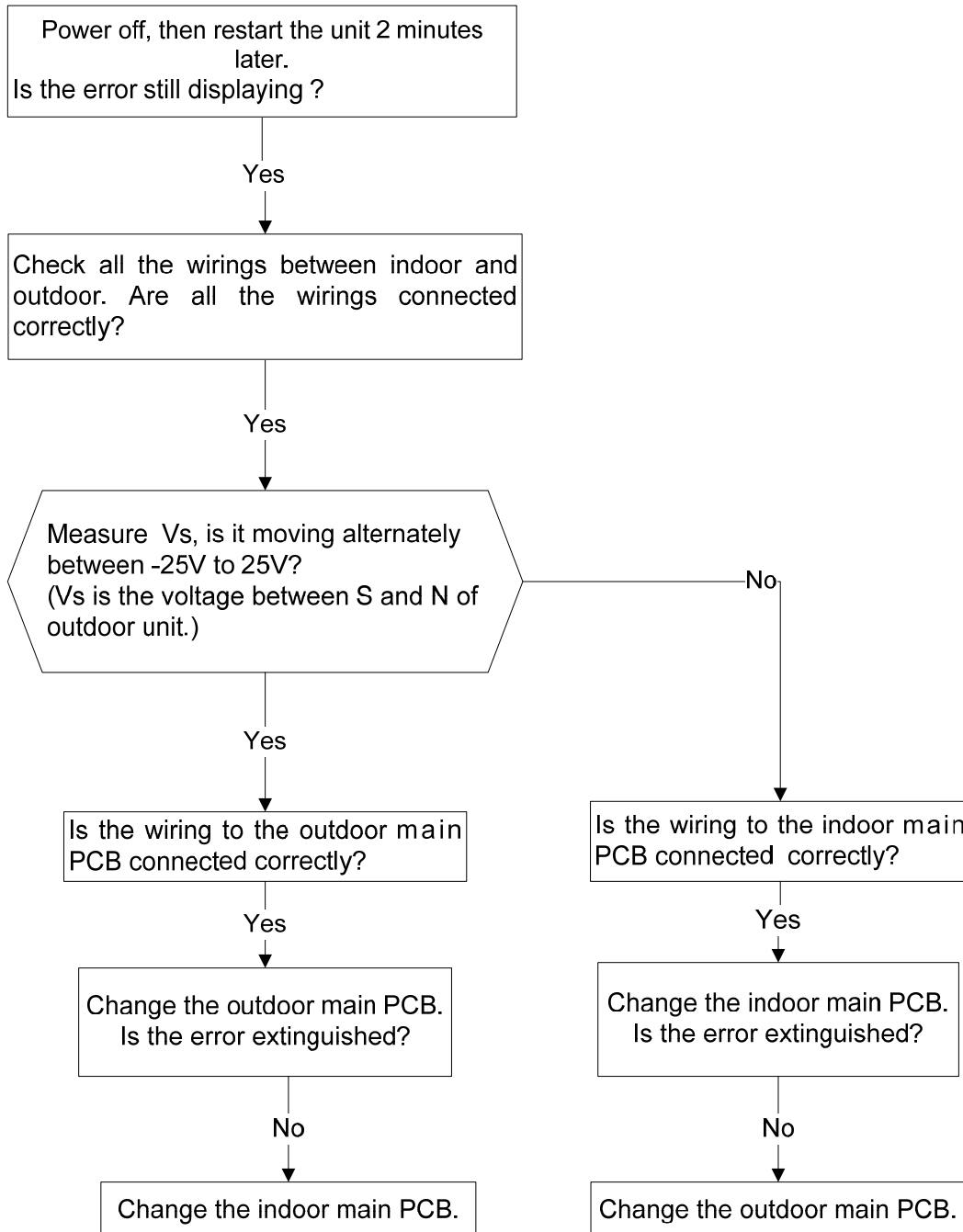

11.2.3 Zero crossing detection error diagnosis and solution (E2)

Error Code	E2
Malfunction decision conditions	When PCB does not receive zero crossing signal feedback for 4 minutes or the zero crossing signal time interval is abnormal.
Supposed causes	<ul style="list-style-type: none"> ● Connection mistake ● PCB faulty

Trouble shooting:

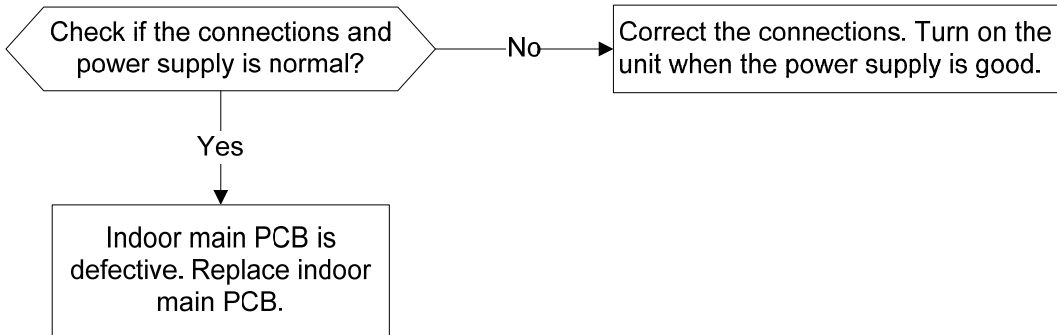

11.2.4 Fan speed has been out of control diagnosis and solution (E3)

Error Code	E3
Malfunction decision conditions	When indoor fan speed keeps too low (300RPM) for certain time, the unit will stop and the LED will display the failure.
Supposed causes	<ul style="list-style-type: none"> ● Wiring mistake ● Fan ass’y faulty ● Fan motor faulty ● PCB faulty

Trouble shooting:

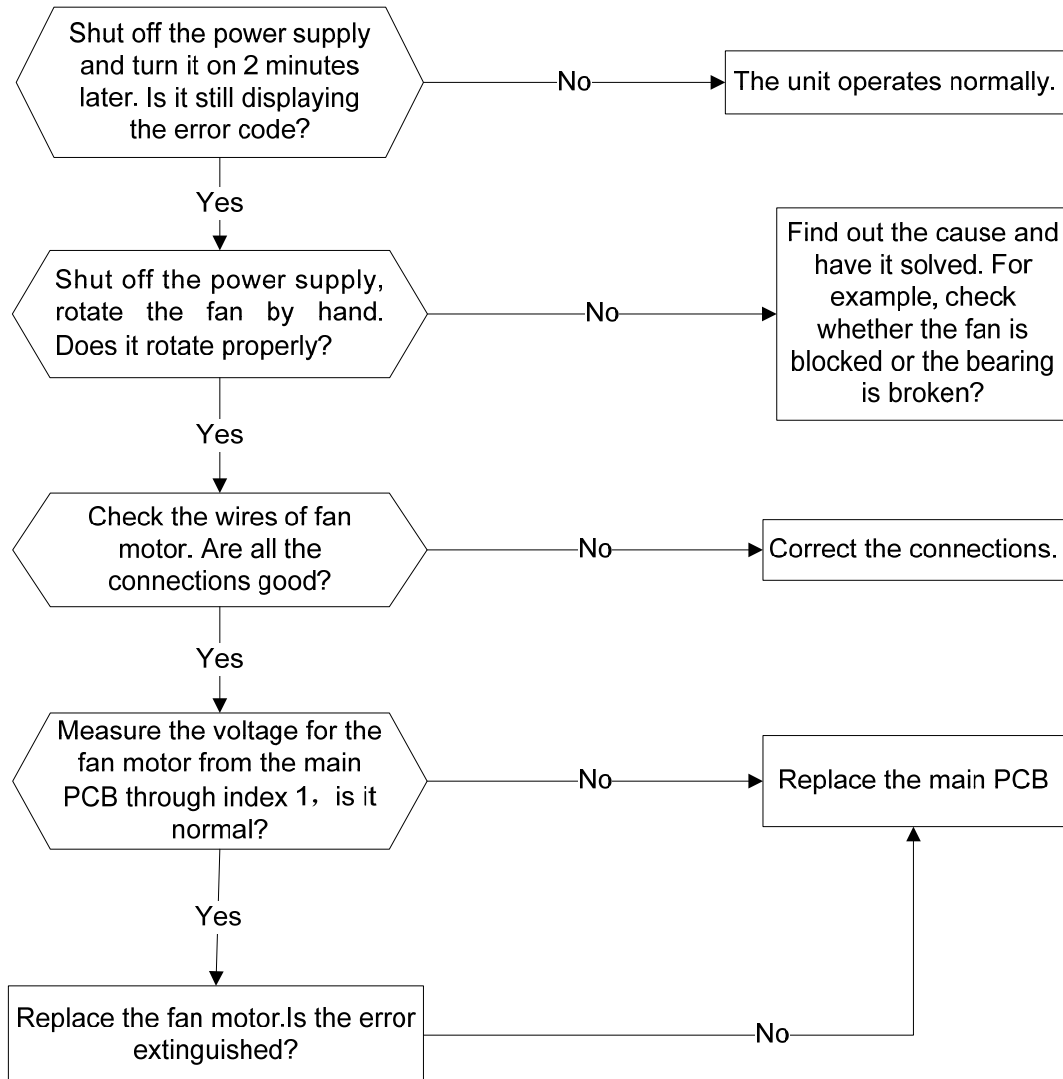

Index1:

1: Indoor AC Fan Motor

Power on and set the unit running in fan mode at high fan speed. After running for 15 seconds, measure the voltage of pin1 and pin2. If the value of the voltage is less than 100V(208~240V power supply)or 50V(115V power supply), the PCB must has problems and need to be replaced.

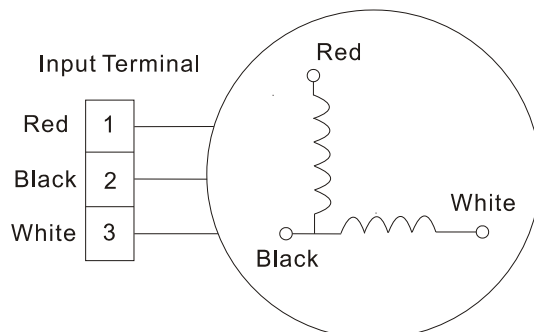

11.2.5 Open circuit or short circuit of temperature sensor diagnosis and solution (E4)

Error Code	E4/E5/F2
Malfunction decision conditions	If the sampling voltage is lower than 0.06V or higher than 4.94V, the LED will display the failure.
Supposed causes	<ul style="list-style-type: none"> ● Wiring mistake ● Sensor faulty ● PCB faulty

Trouble shooting:

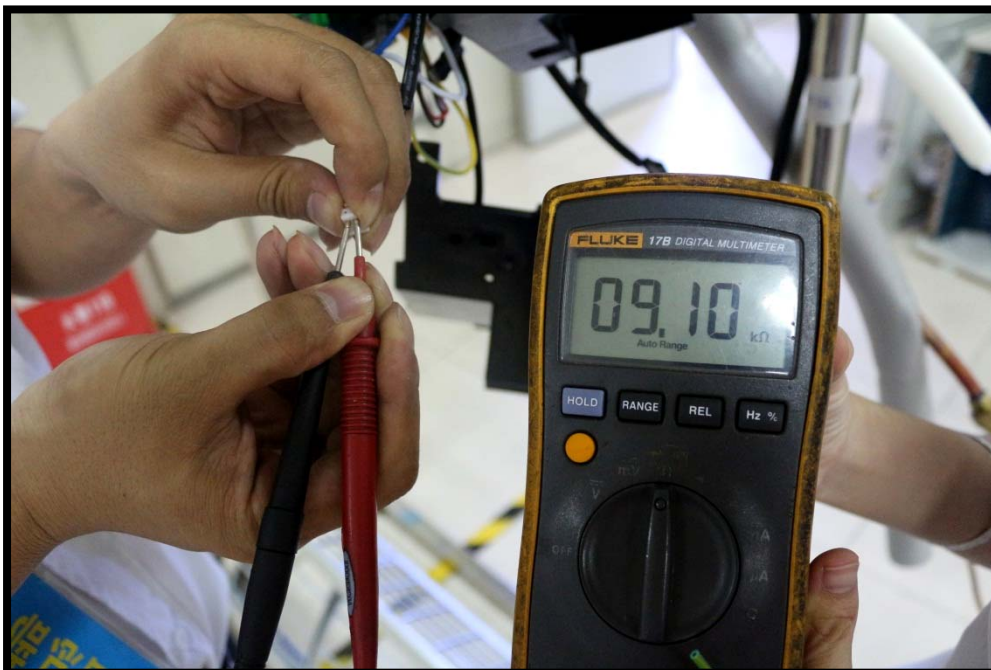
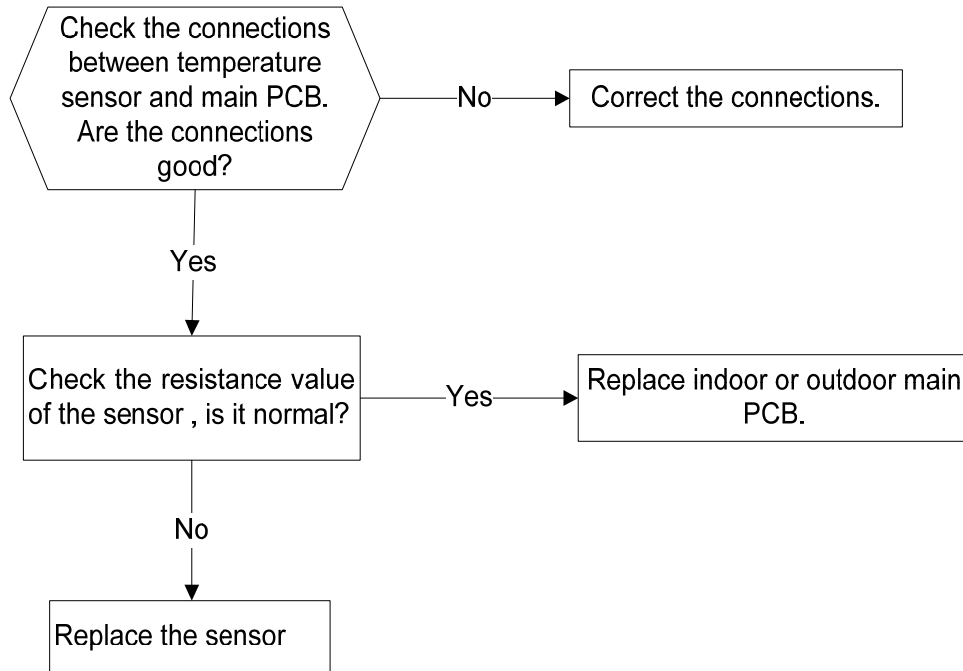

11.2.6 Indoor PCB /Display board communication error (E7)

Error Code	E7
Malfunction decision conditions	Indoor PCB does not receive feedback from Display board.
Supposed causes	<ul style="list-style-type: none"> ● Wiring mistake ● PCB faulty ● Display board malfunction

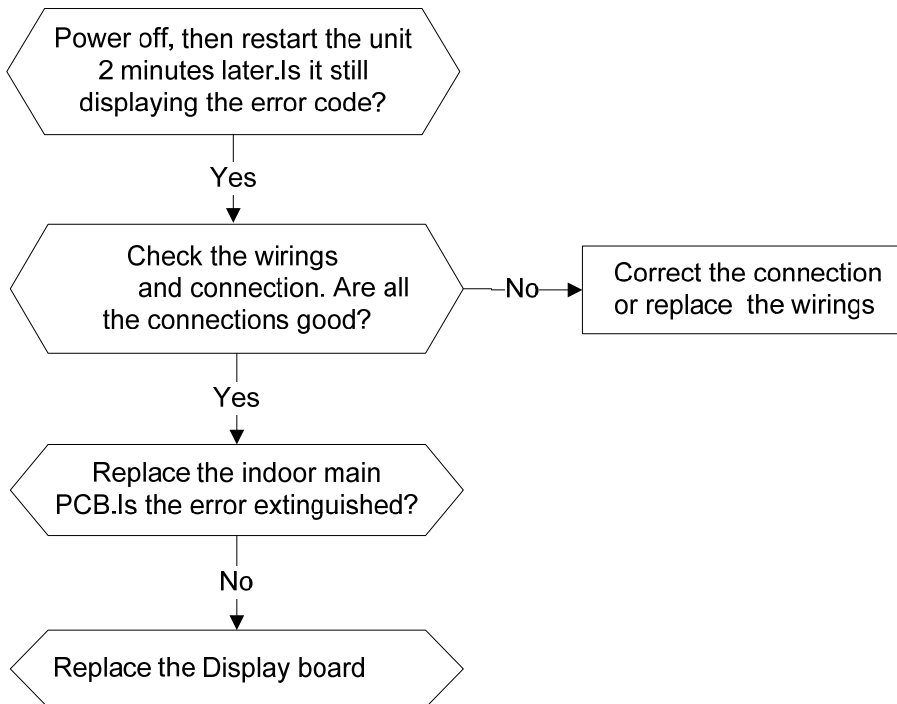
Trouble shooting:

11.2.7 Refrigerant Leakage Detection diagnosis and solution(EC)

Error Code	EC
Malfunction decision conditions	<p>Define the evaporator coil temp.T2 of the compressor just starts running as Tcool.</p> <p>In the beginning 5 minutes after the compressor starts up, if $T2 < T_{cool} - 2^{\circ}C$ does not keep continuous 4 seconds and this situation happens 3 times, the display area will show “EC” and AC will turn off.</p>
Supposed causes	<ul style="list-style-type: none"> ● T2 sensor faulty ● Indoor PCB faulty ● System problems, such as leakage or blocking.

Trouble shooting:

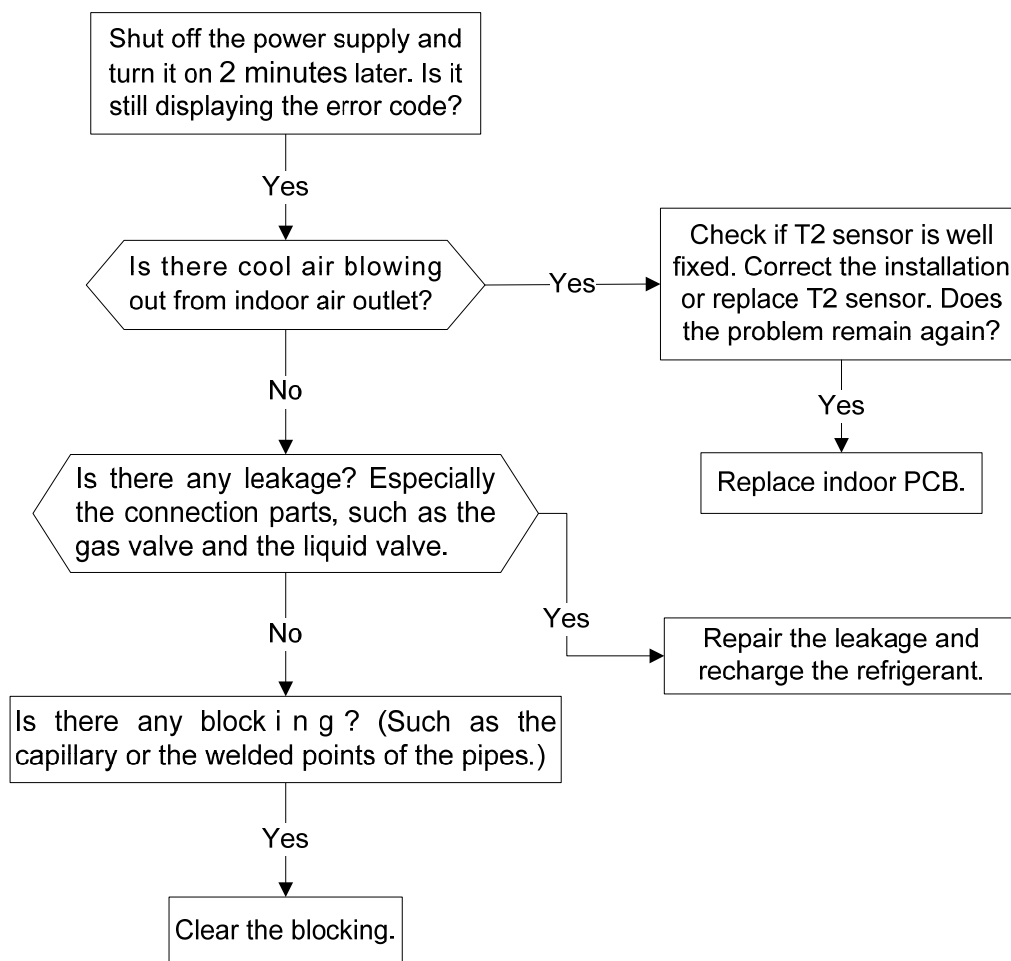

Main parts check

1. Temperature sensor checking

Disconnect the temperature sensor from PCB, measure the resistance value with a tester.

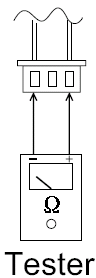

Temperature Sensors.

Room temp.(T1) sensor,

Indoor coil temp.(T2) sensor,

Outdoor coil temp.(T3) sensor,

Outdoor ambient temp.(T4) sensor,

Compressor discharge temp.(T5) sensor.

Measure the resistance value of each winding by using the multi-meter.

Appendix 1 Temperature Sensor Resistance Value Table for T1,T2,T3,T4 (°C--K)

°C	°F	K Ohm	°C	°F	K Ohm	°C	°F	K Ohm	°C	°F	K Ohm
-20	-4	115.266	20	68	12.6431	60	140	2.35774	100	212	0.62973
-19	-2	108.146	21	70	12.0561	61	142	2.27249	101	214	0.61148
-18	0	101.517	22	72	11.5	62	144	2.19073	102	216	0.59386
-17	1	96.3423	23	73	10.9731	63	145	2.11241	103	217	0.57683
-16	3	89.5865	24	75	10.4736	64	147	2.03732	104	219	0.56038
-15	5	84.219	25	77	10	65	149	1.96532	105	221	0.54448
-14	7	79.311	26	79	9.55074	66	151	1.89627	106	223	0.52912
-13	9	74.536	27	81	9.12445	67	153	1.83003	107	225	0.51426
-12	10	70.1698	28	82	8.71983	68	154	1.76647	108	226	0.49989
-11	12	66.0898	29	84	8.33566	69	156	1.70547	109	228	0.486
-10	14	62.2756	30	86	7.97078	70	158	1.64691	110	230	0.47256
-9	16	58.7079	31	88	7.62411	71	160	1.59068	111	232	0.45957
-8	18	56.3694	32	90	7.29464	72	162	1.53668	112	234	0.44699
-7	19	52.2438	33	91	6.98142	73	163	1.48481	113	235	0.43482
-6	21	49.3161	34	93	6.68355	74	165	1.43498	114	237	0.42304
-5	23	46.5725	35	95	6.40021	75	167	1.38703	115	239	0.41164
-4	25	44	36	97	6.13059	76	169	1.34105	116	241	0.4006
-3	27	41.5878	37	99	5.87359	77	171	1.29078	117	243	0.38991
-2	28	39.8239	38	100	5.62961	78	172	1.25423	118	244	0.37956
-1	30	37.1988	39	102	5.39689	79	174	1.2133	119	246	0.36954
0	32	35.2024	40	104	5.17519	80	176	1.17393	120	248	0.35982
1	34	33.3269	41	106	4.96392	81	178	1.13604	121	250	0.35042
2	36	31.5635	42	108	4.76253	82	180	1.09958	122	252	0.3413
3	37	29.9058	43	109	4.5705	83	181	1.06448	123	253	0.33246
4	39	28.3459	44	111	4.38736	84	183	1.03069	124	255	0.3239
5	41	26.8778	45	113	4.21263	85	185	0.99815	125	257	0.31559
6	43	25.4954	46	115	4.04589	86	187	0.96681	126	259	0.30754
7	45	24.1932	47	117	3.88673	87	189	0.93662	127	261	0.29974
8	46	22.5662	48	118	3.73476	88	190	0.90753	128	262	0.29216
9	48	21.8094	49	120	3.58962	89	192	0.8795	129	264	0.28482
10	50	20.7184	50	122	3.45097	90	194	0.85248	130	266	0.2777
11	52	19.6891	51	124	3.31847	91	196	0.82643	131	268	0.27078
12	54	18.7177	52	126	3.19183	92	198	0.80132	132	270	0.26408
13	55	17.8005	53	127	3.07075	93	199	0.77709	133	271	0.25757
14	57	16.9341	54	129	2.95896	94	201	0.75373	134	273	0.25125
15	59	16.1156	55	131	2.84421	95	203	0.73119	135	275	0.24512
16	61	15.3418	56	133	2.73823	96	205	0.70944	136	277	0.23916
17	63	14.6181	57	135	2.63682	97	207	0.68844	137	279	0.23338
18	64	13.918	58	136	2.53973	98	208	0.66818	138	280	0.22776
19	66	13.2631	59	138	2.44677	99	210	0.64862	139	282	0.22231

Appendix 2 Temperature Sensor Resistance Value Table for T5 (°C --K)

°C	°F	K Ohm	°C	°F	K Ohm	°C	°F	K Ohm	°C	°F	K Ohm
-20	-4	542.7	20	68	68.66	60	140	13.59	100	212	3.702
-19	-2	511.9	21	70	65.62	61	142	13.11	101	214	3.595
-18	0	483	22	72	62.73	62	144	12.65	102	216	3.492
-17	1	455.9	23	73	59.98	63	145	12.21	103	217	3.392
-16	3	430.5	24	75	57.37	64	147	11.79	104	219	3.296
-15	5	406.7	25	77	54.89	65	149	11.38	105	221	3.203
-14	7	384.3	26	79	52.53	66	151	10.99	106	223	3.113
-13	9	363.3	27	81	50.28	67	153	10.61	107	225	3.025
-12	10	343.6	28	82	48.14	68	154	10.25	108	226	2.941
-11	12	325.1	29	84	46.11	69	156	9.902	109	228	2.86
-10	14	307.7	30	86	44.17	70	158	9.569	110	230	2.781
-9	16	291.3	31	88	42.33	71	160	9.248	111	232	2.704
-8	18	275.9	32	90	40.57	72	162	8.94	112	234	2.63
-7	19	261.4	33	91	38.89	73	163	8.643	113	235	2.559
-6	21	247.8	34	93	37.3	74	165	8.358	114	237	2.489
-5	23	234.9	35	95	35.78	75	167	8.084	115	239	2.422
-4	25	222.8	36	97	34.32	76	169	7.82	116	241	2.357
-3	27	211.4	37	99	32.94	77	171	7.566	117	243	2.294
-2	28	200.7	38	100	31.62	78	172	7.321	118	244	2.233
-1	30	190.5	39	102	30.36	79	174	7.086	119	246	2.174
0	32	180.9	40	104	29.15	80	176	6.859	120	248	2.117
1	34	171.9	41	106	28	81	178	6.641	121	250	2.061
2	36	163.3	42	108	26.9	82	180	6.43	122	252	2.007
3	37	155.2	43	109	25.86	83	181	6.228	123	253	1.955
4	39	147.6	44	111	24.85	84	183	6.033	124	255	1.905
5	41	140.4	45	113	23.89	85	185	5.844	125	257	1.856
6	43	133.5	46	115	22.89	86	187	5.663	126	259	1.808
7	45	127.1	47	117	22.1	87	189	5.488	127	261	1.762
8	46	121	48	118	21.26	88	190	5.32	128	262	1.717
9	48	115.2	49	120	20.46	89	192	5.157	129	264	1.674
10	50	109.8	50	122	19.69	90	194	5	130	266	1.632
11	52	104.6	51	124	18.96	91	196	4.849			
12	54	99.69	52	126	18.26	92	198	4.703			
13	55	95.05	53	127	17.58	93	199	4.562			
14	57	90.66	54	129	16.94	94	201	4.426			
15	59	86.49	55	131	16.32	95	203	4.294			
16	61	82.54	56	133	15.73	96	205	4.167			
17	63	78.79	57	135	15.16	97	207	4.045			
18	64	75.24	58	136	14.62	98	208	3.927			
19	66	71.86	59	138	14.09	99	210	3.812			